

## Features

- Designed for 12V agricultural equipment
- 4 Nm, 110 rpm @ output shaft
- Custom versions upon request.
- CANOpen communication (speed and position control)
- Integrated brushless motor drive
- Signalling LED
- 2 digital inputs (e.g. seed sensor or hopper level sensor)
- GORE vent
- **ROJ protocol (54T01145) or Arag protocol (54T01125) or WiFi protocol (54T01151) variants**

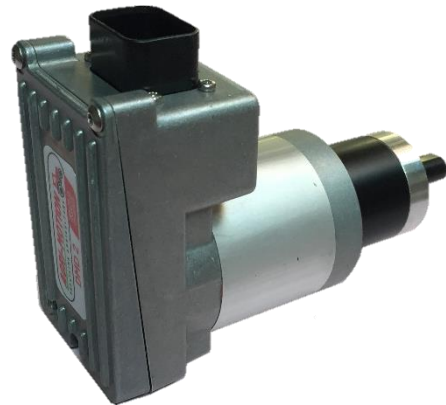

## Applications

The DMD2 is an application specific brushless motor with integrated planetary gearbox and electronic drive. The motor can be used to replace mechanical or hydraulics transmissions in agricultural or other off-highway applications (e.g. variable rate applications).

Application example are:

- Actuation of seeding element in pneumatic precision planting machines
- Actuation of seed distributor in air-drills or small grain planters
- Actuation of fertilizer and microgranular spreaders in agricultural machines
- Salt, fertilizer, grain spreaders

## Overall dimensions

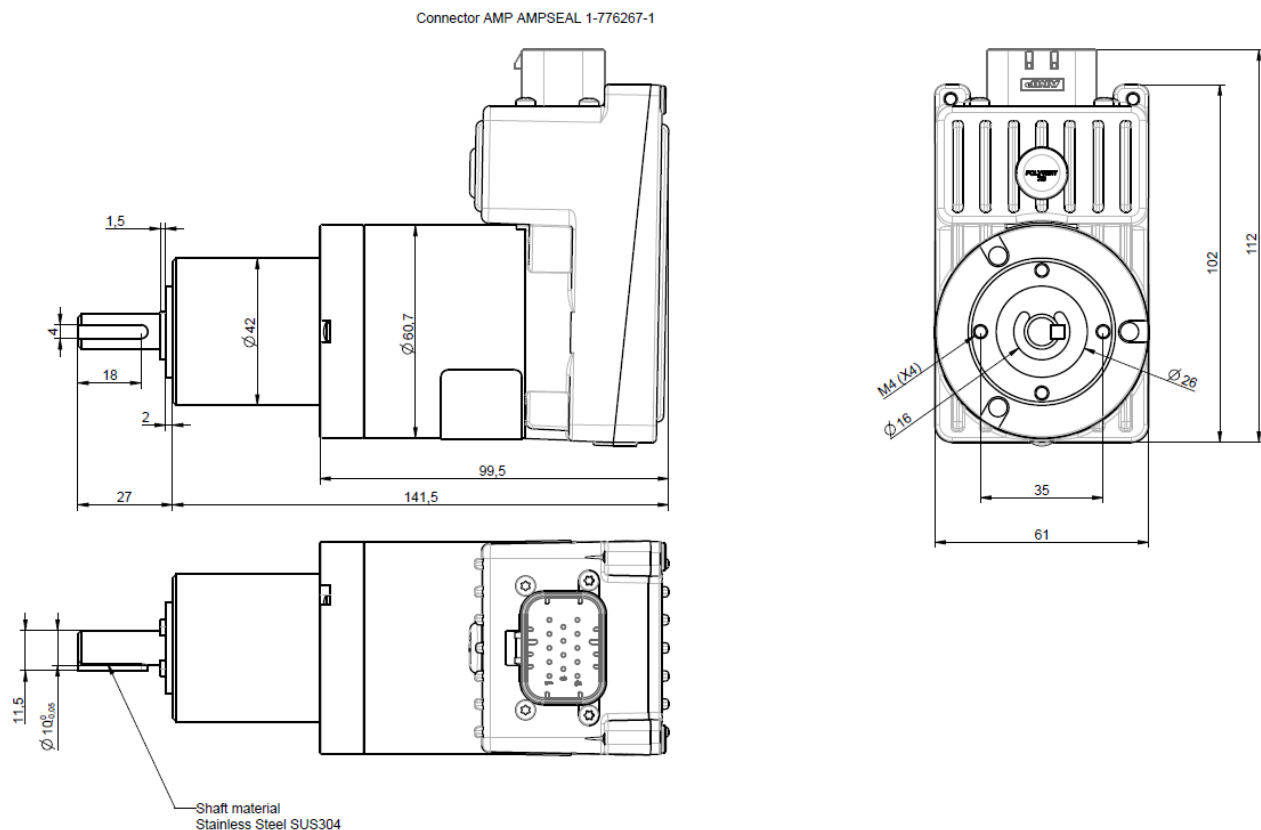

## Mechanical Specifications

Nominal Torque at output shaft	4 Nm
Peak Torque at output shaft	6 Nm (single pulse, duration 500ms)
Nominal Speed at output shaft	110 rpm
Gear ratio of integrated gear	1:26.85 axial planetary gear

## Environmental Specifications

Operational Temperature:	-10°C...+55°C (full specs) -10°C...+70°C (derated)
Storage Temperature:	-40°C...+80°C
IP grade	IP65 excluding the front flange/output shaft. Note: the system integrator shall provide means of protecting those surfaces when integrating the motor into the machine
Vibrations	Sinusoidal vibration test: IEC 600-68-2-6 Random vibration test: IEC 600-68-2-64 Temperature change test: IEC 60068-2-14 Shock test: IEC 600-68-2-27

## Electrical Specifications

EMC	The unit fulfills EN ISO 14982: 2009 standard (Agricultural and forestry machinery)
Supply voltage	11-16V Note: Voltage is intended at MD connector input pins. Voltage drop due to cable harness shall be taken into account.
Supply current	7,2 A (at nominal Torque, nominal Speed and minimum supply voltage)

## Input/output and communication

CAN	1 CAN bus line (compliant ISO SO 11898-2 and 5. Up to 1 Mbit/s)
Sensor interface	2 x inputs: 3 pins (8V – 80mA supply, GND, signal), up to 2,5 kHz suitable for NPN output sensors.
Safety switch input	Contact switch input to remove supply to power stage.
Daisy Chain CAN addressing line	Input and output signal for automatic CAN node assignment

## Connector pin-out

Motor connector matches with AMP Ampseal 14 poles, with the following pinning. It matches with connector AMP Ampseal 776273-1.

1	POWER INPUT (+12V)	6	CAN_H	10	/
2	GND	7	CAN_L	11	/
3	SEED_POWER (+8V)	8	MOTOR_ENABLE_OUT	12	MOTOR_ENABLE_IN
4	SEED_POWER (+8V)	9	SEED_SENSOR_CNT	13	GND
5	AUX_IN	/	/	14	GND

## Safety switch

A safety switch shall be connected to signals MOTOR\_ENABLE\_IN/ MOTOR\_ENABLE\_OUT. If the contact is open, the DMD cannot rotate. The safety switch must be implemented using:

- an electro-mechanical switch with “positive opening” NC contact (condition indicated by the symbol  $\ominus$ ), or
- an electromagnetic sensor with high reliability (e.g. SICK RE11-SA03 or equivalent)
- In order to ensure the requested safety level (Performance Level = c according to EN ISO 13849-1), it is necessary to provide a safety contact with the following characteristics:  $B10_d \geq 2 \cdot 10^6$

Note:  $B10_d$  is the reliability parameter declared by the device Manufacturer that corresponds to the number of switching operations guaranteed without errors.

## Installation

The fastening of motors to the machine, whether they are used for the seeding disc shaft or the fertilizer or micro-granular distributor shaft rotation, must be carried out in order to ensure a perfectly aligned coupling between the disk/distributor shaft and the gear output shaft.



*In the absence of a perfect alignment, radial forces may occur on the bearings, causing an increase of the necessary torques and a reduction of the device life.*

*In order to relieve the bearing stress, an elastic coupling can be used. This one is not supplied with the motor kit and it must be chosen and dimensioned according to the application.*

## Output shaft axial/radial forces limitations

- Maximum axial load: 100N
- Maximum radial load: 200N

## Orientation limits

It is preferable to mount the DMD2 motor so that the connector is facing downward to prevent stagnation of water over the sealing gaskets.

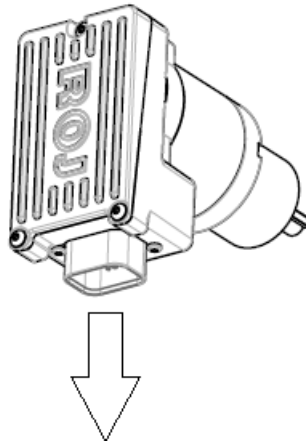

## Water ingress protection

Motor has a **IP65** rating, excluding the front flange/output shaft.

## Disclaimer

The present specifications are intended to be preliminary. Parameters and values indicated in the document might be subjected to changes. For further information, please contact: [mechatronics@roj.com](mailto:mechatronics@roj.com)

**For more details, please refer to DMD2 Installation, Operation and Maintenance Manual**