

ROJ

CE



PCS 150

**Installation
Use
Maintenance**

ORIGINAL INSTRUCTIONS

PCS 150 – Rev. 1.1 – August 2022

Copyright - ROJ - All Rights Reserved.

This manual is meant for the **PCS 150 Kit** users.

ROJ reserves the right to modify at any time the content of this Manual without giving prior notice to the user.

For any technical or commercial problems, please contact your local ROJ dealer or call directly ROJ customer service center. We will be glad to fulfill all your needs.

Thank you for your trust and good job.

The PCS 150 is a patented equipment which employs exclusive and high-tech solutions.

PCS 150

INSTALLATION, USE AND MAINTENANCE MANUAL

Edition: August 2022
Revision: 1.1

Headquarters and Production plant:

ROJ

Via Vercellone 11

13900 Biella (BI)



Tel. +39 015 84 80 111









Fax +39 015 84 80 209

E-mail: comm@roj.com

www.roj.it

INDEX	<i>i</i>
INTRODUCTION	<i>v</i>
SAFETY	<i>vi</i>
CE IDENTIFICATION PLATE	<i>vi</i>
COMPLIANCE WITH THE EUROPEAN DIRECTIVES AND REGULATIONS	<i>vii</i>
WARRANTY AND RESPONSIBILITY OF THE MANUFACTURER	<i>viii</i>
OTHER WARRANTY TERMS	<i>viii</i>
1. GENERAL INFORMATION	<i>1.1</i>
1.1. INTRODUCTION	<i>1.1</i>
1.1.1. The ideal solution to control and optimize the transplanting process	<i>1.1</i>
1.1.2. Purposes of this manual	<i>1.1</i>
1.1.3. How to Read this Manual	<i>1.1</i>
1.1.4. Symbols used.....	<i>1.2</i>
1.1.5. Environment protection	<i>1.2</i>
1.2. GENERAL INFORMATION AND PERFORMANCES	<i>1.3</i>
1.2.1. Introduction	<i>1.3</i>
1.2.2. Functional blocks (Ref. Fig. 1-1).....	<i>1.3</i>
1.2.3. Machines on which the integration of the mentioned partly completed machinery is foreseen.....	<i>1.4</i>
1.2.4. Acronyms used	<i>1.4</i>
1.3. COMPONENTS OF THE PCS 150 KIT	<i>1.5</i>
1.4. GENERAL SAFETY INFORMATION	<i>1.8</i>
1.4.1. Design criteria	<i>1.8</i>
1.4.2. Safety Devices and Solutions.....	<i>1.9</i>
1.4.3. Warning about Residual Risks	<i>1.10</i>
1.4.4. Warnings and Rules of Behaviour for the Operator	<i>1.10</i>
1.4.5. Noise level emitted	<i>1.11</i>
1.4.6. Proper and Improper Use	<i>1.11</i>
1.4.7. Reliability of the safety-related control systems	<i>1.11</i>
2. INSTALLATION	<i>2.1</i>
2.1. FEATURES OF THE DMD0 e DMD2 (MD) GEARED MOTORS	<i>2.1</i>
2.2. GEARED MOTOR (MD) INSTALLATION	<i>2.1</i>
2.2.1. General principles	<i>2.1</i>
2.3. DMD0	<i>2.2</i>
2.3.1. Outlet shaft torque and speed	<i>2.2</i>
2.3.2. Outlet shaft dimensions	<i>2.2</i>
2.3.3. Fastening flange characteristics	<i>2.2</i>
2.3.4. Tilt limits	<i>2.2</i>
2.3.5. Transport cap	<i>2.3</i>

2.3.6.	Fastening.....	2.3
2.4.	DMD2	2.5
2.4.1.	Outlet shaft torque, speed and axial/radial loads	2.5
2.4.2.	Overall dimensions of the geared motor and dimensions of the outlet shaft	2.5
2.4.3.	Fixing flange features and geared motor fastening.....	2.5
2.5.	ALTERNATOR.....	2.7
2.5.1.	Pulleys and rotation direction.....	2.7
2.5.2.	Absorbed mechanical power and radial loads.....	2.7
2.6.	BATTERY.....	2.9
2.7.	SPEED SENSOR	2.9
2.7.1.	Single cogwheel sensor.....	2.9
2.7.2.	Wheel sensor check	2.10
2.7.3.	Magnetic encoder	2.11
2.7.4.	Magnetic encoder control	2.12
2.8.	MACHINE POSITION SENSOR.....	2.12
2.8.1.	Position sensor check.....	2.13
2.9.	ECU POSITIONING.....	2.13
2.10.	SDB POSITIONING.....	2.14
2.11.	WIRING DIAGRAM	2.14
2.11.1.	Main components	2.15
2.11.2.	Connection ECU.....	2.15
2.11.3.	SDB and power supply cables connection	2.16
2.11.4.	Connection MD.....	2.19
2.11.5.	Safety switch	2.21
3.	USER MANUAL.....	23
3.1.	MACHINE START UP	23
3.2.	GRAPHIC ORGANIZATION	24
3.3.	ACCESS LEVELS.....	25
3.4.	MOTOR ADDRESSING	26
3.4.1.	Machine configuration	27
3.4.2.	Addressing	28
3.5.	MACHINE CONFIGURATION	30 
3.5.1.	Machine tab.....	30
3.5.2.	Distributor tab	32
3.5.3.	Fertilizer spreader/A Microgranulator A/B Microgranulator Tab.....	33
3.5.4.	Rows MD Configuration.....	34
3.5.5.	"Volume per revolution" measurement.....	35
3.6.	SETTINGS	37 
3.6.1.	Machine tab.....	37
3.6.2.	Speed sensor calibration	38
3.6.3.	Distributor tab.....	39

3.6.4.	Fertilizer spreader/A Microgranulator A/B Microgranulator Tab.....	41	
3.7.	HOME PAGE	42	
3.7.1.	Row management	44	
3.7.2.	Summary information about the job	45	
3.7.3.	Synoptic	46	
3.7.4.	Distributors pop-up windows	47	
3.7.5.	Disable distributor	48	
3.7.6.	Fertilizer spreader, A and B micro-granulators pop-up windows	48	
3.7.7.	Transplanting job.....	50	
3.8.	ALARMS.....	51	
3.9.	USB MENU, SOFTWARE UPDATE AND PROTOCOL CHANGE	3.1	
3.9.1.	Software update	3.2	
3.9.2.	HMI software update	3.3	
3.9.3.	ECU software update.....	3.4	
3.9.4.	How to confirm the addressing and restore parameters	3.5	
3.9.6.	MD software update	3.6	
3.9.7.	MD protocol change	3.8	
3.10.	STATISTICS	3.9	
3.10.1.	Statistics.....	3.10	
3.10.2.	Distributors statistics	3.11	
3.10.3.	Event log.....	3.12	
3.10.4.	Event and statistics storage.....	3.13	
3.11.	TERMINAL	3.14	
3.12.	TEST	3.17	
4.	MAINTENANCE AND TROUBLESHOOTING	4.1	
4.1.	GENERAL INFORMATION ABOUT MAINTENANCE.....	4.1	
4.2.	ORDINARY PREVENTIVE MAINTENANCE TASKS TO BE CARRIED OUT BY THE OPERATOR	4.1	
4.3.	MAINTENANCE / REPAIR TASKS ONLY ALLOWED TO SPECIALIZED PERSONNEL.....	4.2	
4.4.	SPARE PARTS.....	4.3	
4.5.	PROCEDURE FOR THE MD REPLACEMENT OR EXCHANGE	4.5	
4.5.1.	Replacing the MD with a new MD	4.5	
4.5.2.	Exchanging the faulty motor with another functioning motor already installed on the machine.....	4.5	
4.5.3.	Removing the MD from the machine configuration	4.6	
SUMMARY OF UPDATES			

9/18/2014	Rev. 1.0
8/18/2022	Rev. 1.1

INTRODUCTION

All machines ⁽¹⁾ and equipment designed and manufactured by **ROJ** are supplied with the relative user's manuals in compliance with the Essential Health and Safety Requirements (EHSRs) 1.7.4 - *Instructions* – of Annex I to Machinery Directive 2006/42/EC.

As the prescriptions of Machinery Directive, and in particular the EHSRs of Annex 1 represent **mandatory law obligations**, during the wording of his manuals, ROJ paid particular attention to all the requirements listed in EHSR 1.7.4, in particular:

1. The **ROJ** user and maintenance manuals are supplied in the language of the machine destination country, within the European Union and, if necessary, a copy of the manual in the “original language” is also provided.
2. The **ROJ** manuals always contain a “proforma” copy of the EC Declaration of Conformity (or a “proforma” copy of the Declaration of Incorporation of the “Partly completed machinery” for the relevant machine. These copies are only meant for informative purposes, and they shall not be considered substitutive of the original Declaration of Conformity Incorporation subscribed by the supplier, and delivered separately to the Customer.
3. The **ROJ** User and Maintenance Manuals contain some information deemed as important and necessary by the Manufacturer in order to:
 - Understand the principle of operation of the machine⁽¹⁾.
 - Carry out the handling/mounting/installation and connection operations under **Safety Conditions** taking into account the possible hazards connected with the abovementioned activities and providing the indications, prescriptions and suggestions resulting from a careful risk assessment performed by the Manufacturer following the principles of the EN ISO 12100:2010 Type C Harmonized Standard and the ISO/TR 14121-2:2013 Guidance to Risk Assessment.
 - Correctly use the machine (control devices, safety and emergency devices, operating procedures, etc.) under **Safety Conditions**, drawing the operator's attention possible “Residual Risks”, i.e., the risks that remain notwithstanding all the safety measures adopted after performing the risk assessment, as indicated in the previous point.
 - Carry out the ordinary/preventive maintenance operations on the machine ⁽¹⁾ under **Safety Conditions**, drawing even in this case the maintenance technician's attention to the possible Residual Risks.
4. The ROJ User and Maintenance Manuals describe not only the intended uses of the machine ⁽¹⁾, but also the reasonably expected misuses, according to the experience accrued by the Manufacturer.

SAFETY

In relation to the risk analysis and assessment activities carried out on the PCS 150 Kit in accordance with the principles of the EN ISO 12100: 2010 Harmonized Standard (as described in 3 above), the machine manufacturer or the final system integrator selects the various components of the safety related control systems (e.g. micro-switches on the guards of the transplanting elements), in a way as to ensure a reliability level suitable to the actual severity of the hazard (typically Performance Level “c”). To this purpose we have followed the requirements of the EN ISO 13849-1:2015 Harmonized Standard.

The **ROJ**⁽¹⁾ kit complies with the Immunity and Electromagnetic Radiation Limits defined by the Harmonized Standard for agricultural and forestry machinery EN ISO 14982:2009.

The **ROJ** User and Maintenance Manuals contain the updated list of the harmonized standards applied during the design phase in order to guarantee the compliance with the Essential Safety Requirement Listed on Annex I of 2006/42/EC Directive, while the design and implementation details are described on the Technical Documentation kept by the manufacturer according to the prescriptions of Machinery Directive 2006/42/EC.

(1) The term "Machine" used within this manual refers generically to the definition given in 2006/42/EC Directive and thus combines both complete machines able to carry out a well-defined function and "Partly completed machinery" or equipment or drive systems not able to perform a defined function as they are intended to be incorporated in a complete Machine.

CE IDENTIFICATION PLATE

The ROJ PCS xxx kits are CE marked on the back of the graphic display.



COMPLIANCE WITH THE EUROPEAN DIRECTIVES AND REGULATIONS

Herein under is a summary of the **Declaration of Incorporation**, drawn up in accordance with the requirements of Annex II B to the 2006/42/EC Directive, where **ROJ** declares that the following “Partly completed machinery”:

Type:	PCS 150 (PCS 100, PCS 200) ^{Footnote 1}
Construction Year:	See official Declaration of Incorporation
Serial number:	See official Declaration of Incorporation
Target use:	Servo power supply for seeders

cannot be commissioned unless the compliance of the agricultural machinery on which it has to be incorporated with the requirements of the 2006/42 /EC Directive - Annex II A - related to the machine safety is ensured by the Manufacturer of the agricultural machinery or the system integrator and that for its design and manufacturing the principles and concepts introduced by the applicable paragraphs of the following Harmonized Standards have been adopted:

- EN ISO 12100:2010
- EN ISO 13849-1:2015
- EN ISO 4254-1:2015
- EN ISO 14982:2009
- EN ISO 13849-2:2012
- EN ISO 4254-9:2018

The PCS 150 Kit complies with the requirements of the EMC 2014/30/EU Directive relating to Electromagnetic Compatibility.

The technical documentation is kept at the ROJ Technical Departments (mechatronics@roj.com).

ROJ has complied with the following EHSRs (Essential Health and Safety Requirements) Annex 1 to the Machinery Directive 2006/42/CE:

[1.1.1](#) – [1.1.2](#) – [1.1.3](#) – [1.3.2](#) – [1.3.4](#) – [1.3.7](#) – [1.3.8](#) – [1.5.5](#) – [1.5.10](#) – [1.5.11](#) – [1.6.1](#) – [1.7.1](#) – [1.7.2](#) – [1.7.3](#) – [1.7.4](#)

The manufacturer of the agricultural machinery or the system integrator must ensure compliance to all the applicable EHSRs not mentioned in the above list.

ROJ agrees to send all the relevant information about the Agri-Motion X-tend partly completed machinery via email or FTP, upon reasonable request made by the relevant national authorities.



The above information is merely indicative and shall not be considered as replacing the original Declaration of Incorporation signed and released by the Manufacturer.

Note 1: The PCS FS and PCS 150 kits are a subset of the PCS 200 kit

WARRANTY AND RESPONSIBILITY OF THE MANUFACTURER

The **PCS 150** system described in this manual has been designed to be incorporated into agricultural machinery (*typically Transplanters*) and is therefore intended to operate exclusively in combination with the above mentioned machines.

The various components of the system on the transplanter can be installed by:

- the Transplanter machine manufacturer
- **ROJ** specialized and authorized technicians

The testing and commissioning of the system is in any case entrusted to specialized personnel.

ROJ declines any responsibility in case of improper installation of the system not following the instructions given in this manual or if the system is commissioned without an authorization by **ROJ**.

The end user must ensure that the equipment is used in accordance with the laws and regulations in force in the country of installation, in particular as far as the workers safety is concerned, and more generally in relation to the health, safety and accident prevention requirements.

Any complaint must be promptly notified upon detection of any defect attributable to the **PCS 150** system components.

If, after an accurate assessment, the complaint is deemed as admissible, **ROJ** may, at its sole discretion, replace or repair the defective components.

OTHER WARRANTY TERMS

ROJ warrants the quality and reliability of the equipment that has been designed and manufactured to provide optimal performance.

The warranty does not cover any damages or indirect costs due to machine downtime or irregular operation caused by improper use of the equipment or of individual **ROJ** devices.

It is the responsibility of the end user to periodically perform cleaning and ordinary preventive maintenance activities, aimed at keeping the equipment operation within the expected performance range.

Any failure or improper equipment connection will void the warranty.

The warranty does not apply in case of floods, fire, electrostatic/inductive discharges or in case of discharges caused by lightning or other phenomena external to the **ROJ** equipment.

The warranty does not cover any damages to operators or other equipment/devices connected to the **ROJ** equipment.

The customer is fully responsible for the proper use and maintenance of the equipment, according to the instructions provided in this user's manual.

This warranty does not cover parts subject to normal wear.

Any other form of warranty is excluded.

1. GENERAL INFORMATION

1.1. INTRODUCTION

1.1.1. The ideal solution to control and optimize the transplanting process

The PCS 150 kit has been designed for the installation on transplanters in order to control and optimize the entire transplanting process.

Thanks to the exclusive flexibility and configurability the PCS 150 kit represents the best solution for cup feed type or belt-driven Transplanters.

1.1.2. Purposes of this manual

This manual aims at providing the PCS 150 Kit users with the essential information to:

- install and properly connect the system components under safe conditions.
- configure the system and set up the various operating parameters according to the user's requirements.
- carry out the preventive maintenance on the system under safe conditions.

1.1.3. How to Read this Manual

The manual is divided into 4 sections:

Section 1 – shows the structure and the components of the system and provides notes and safety warnings, in addition to the technical data of the units that are included in the kit.

Section 2 – describes the necessary operations and procedures for a correct installation and commissioning of the system.

Section 3 – describes the human machine interface, the configuration modes, the parameters setup and all the information for a correct understanding of the alarm and failures messages.

Section 4 – includes information and warnings useful to undertake a correct maintenance of the system.

1.1.4. Symbols used



This symbol highlights the notes, warnings, and points the reader's attention has to be drawn on.



This symbol indicates a particularly delicate situation that could affect the safety or proper functioning of the system.



This symbol indicates the obligation to dispose of a material having an impact on the environment in accordance with the local regulations.



This symbol indicates the tasks that can be performed through a simple but essential visual inspection.

1.1.5. Environment protection



Handling of electrical or electronic equipment at the end of the life cycle (Applicable to all countries of the European Union and to those countries where a separate collection of waste is in force).

This symbol shown on the product or on packaging indicates that the product itself shall not be considered as normal house-waste, but rather that it must be delivered to an appropriate collection point, for recycling of electrical and electronic equipment. By ensuring that this product is properly disposed of, you will help prevent potentially negative consequences for the environment and human health which could otherwise be caused by inappropriate waste handling the same. Proper recycling of the materials will help to protect natural resources. For more details about the recycling procedures for this product, you may contact your municipal technical office, your local waste disposal service or your local dealer.



Always recycle used batteries into special containers. DISPOSE OF BATTERIES AN ENVIRONMENT-FRIENDLY WAY

1.2. GENERAL INFORMATION AND PERFORMANCES

1.2.1. Introduction

The PCS 150 System has been designed to be applied on belt-driven transplanters or transplanter with cups (falling within the scope of the EN 14018: 14018 norm) in order to replace the mechanical transmission that drives the rotation of the transplanting elements and the fertilizer distributor units with electrical engines, operated by their relative control system. This replacement provides a greater machine flexibility and offers new capabilities which cannot be obtained with the simple mechanical transmission.

The basic functions of the system can be summarized as follows:

Transplanting element speed control, in order to deposit the plants at a prescribed distance, regardless of the advancement speed of the tractor.

Speed control of the fertilizer and micro-granular fertilizer spreader in order to distribute a certain quantity of seeds per/ha of covered field

1.2.2. Functional blocks (Ref. Fig. 1-1)

The system consists of the following functional blocks:

- **ECU**: Electronic control unit that manages the various onboard sensors of the machine (speed sensor, proximity switch, etc.) and transfers to MDs both the basic settings and the real-time information needed for transplanting and fertilizing.
- **MD**: Motor integrated drive, used to move the distribution element or to rotate the fertilizer and micro-granular fertilizer spreader.
- An MD is associated to each distribution element, in order that the cups speeds are fully independent for each row.
- One (or more) MDs for the fertilizer spreaders
- One (or more) MDs for the distributors of microgranular fertilizer
- **HMI**: Graphic console allowing the user to set up and read data related to the transplanting activity, to access diagnostic functions, and so on.
- **SDB 12+12**: 12V DC power supply unit with individual fuses (up to 24 motors).
- **SDB 3+3**: 12V DC power supply unit with individual fuses or fuses in pairs (up to 6 motors).
- **Machine position sensor** to determine whether the transplanter is lifted (transport/taxing position) or lowered (working position).
- **Speed sensor**: radar or commercially available wheel proximity sensor which generates an incremental position (or speed) reference of the tractor.
- **Cabling** for the connection of the different devices

1.2.3. Machines on which the integration of the mentioned partly completed machinery is foreseen

Pneumatic precision transplanters for tractors where no ISOBUS connection is required.



The current system version is based on a proprietary architecture and DOES NOT include the ISOBUS connection.

1.2.4. Acronyms used

EHSRs Essential Health and Safety Requirements. Annex 1 of the Machinery Directive.

PL Performance Level (reliability level of the safety functions) according to EN 13849-1

AD Analogue/digital converter

CAN Controller Area Network (BUS)

ECU Electronic control unit

ISOBUS Communication standard for tractors and machinery for agriculture and forestry ISO-11783

MD Motor with integrated drive

PTO Power take-off

SDB Sub distribution board

HMI Human-machine interface console

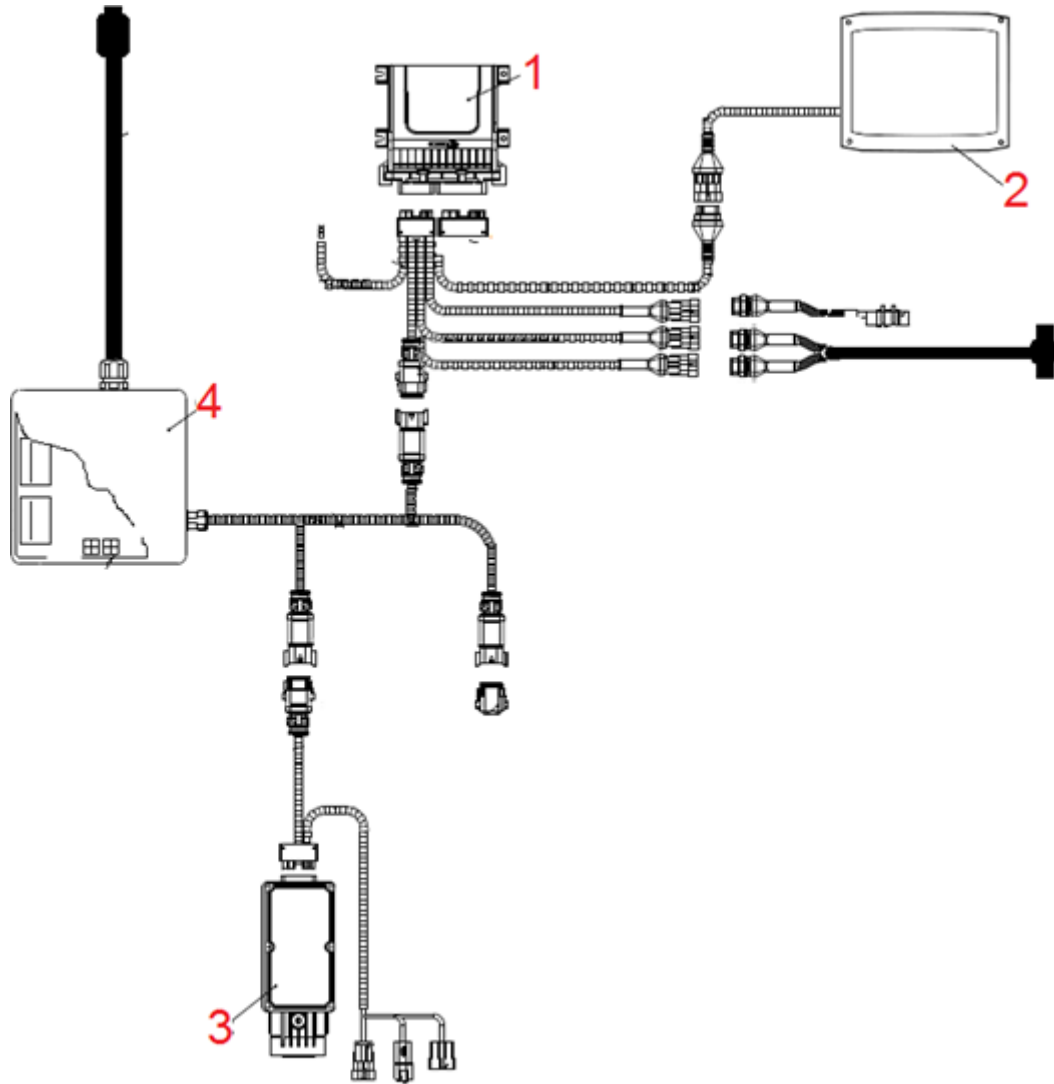

1.3. COMPONENTS OF THE PCS 150 KIT



Picture 1-1 Main components of the PCS 150 kit

TECHNICAL DATA

1	ECU	Electronic Control Unit	Processor: 80 Mhz; Flash memory 2.5 Mb; RAM: 128 Kb; NVRAM: 8 Kb; CAN Bus lines: 3; IP69K protection
2	HMI	Graphic display	7" TFT color display; Resolution: 800 x 400, 18 bpp Resistive touchscreen
3	MD	Geared motors	Rated voltage: 12 VDC; Rated current: 4,2 A; Rated power: 80 W Rated speed: 3000 rpm
4	SDB	Sub distribution board	Power sub distribution board, with fuses

MD	Geared motor for the transplanting elements and the distributors of fertilizer/granular fertilizer	
ECU	Electronic Control Unit	
HMI	Graphic display	

SDB	Sub distribution board	
------------	-------------------------------	--

1.4. GENERAL SAFETY INFORMATION

1.4.1. Design criteria

For the design and construction of the PCS 150 equipment, the principles set out in the relevant paragraphs of the following harmonized Standards have been adopted:

EN ISO 12100: 2010	<i>Safety of machinery - General principles for design - Risk assessment and risk reduction.</i>
EN ISO 4254-1:2015	<i>Agricultural machinery - Safety - Part 1: General requirements.</i>
EN ISO 4254- 9:2018	<i>Agricultural machinery - Safety - Seed drills.</i>
EN ISO 13849-1:2015 (*)	<i>Safety of machinery. Safety-related parts of control systems. Part 1: General principles for design.</i>
EN ISO 13849-2:2012	<i>Safety of machinery - Safety-related parts of control systems. Part 2: Validation.</i>
EN 50581:2012	<i>Technical documentation for the assessment of electrical and electronic products with respect to the restriction of hazardous substances.</i>
EN ISO 14982: 2009	<i>Agricultural and forestry machinery - Electromagnetic compatibility - Test methods and acceptance criteria.</i>

(*) Only applied to the Performance Level Assessment of the safety function on movable guards (responsibility of the seeder manufacturer).

The compliance with the relevant paragraphs of the above Harmonized Standards allowed us to eliminate or reduce as far as possible the risks, both during normal operation and during the adjustment and / or maintenance operations on the equipment, along its whole life cycle.

All components have been carefully selected among those available on the market, and the materials used in manufacturing the system do not pose any risk to the people's health and physical integrity.

Safety measures have also been implemented for the PCS 150 kit in order to eliminate or reduce the residual risks within acceptable limits (see paragraph "Warning about residual risks").

In particular, the Essential Health and Safety Requirements of Annex I to Directive 2006/42/EC listed in the Incorporation Declaration have been complied with.

The compliance with the non-listed requirements must be granted by the manufacturer of the Transplanter or the system integrator and will be verified during the commissioning of the PCS 150 system.

1.4.2. Safety Devices and Solutions

All moving parts of the geared motors are properly protected to prevent mechanical dangers and the electrical parts of the actuator are enclosed in a housing with a minimum IP65 protection rating.

The installation of a safety device (electromechanical micro-switch or electromagnetic sensor) on the guards of distribution elements should be foreseen (by the transplanter manufacturer or by the system integrator) which prevents the geared motor from starting under open guard conditions.



The components of the integrated drive inside the geared motor can only be accessed using suitable tools and exclusively by skilled and authorized staff, when the machine is in stationary position and disconnected from any power source.

Any attempt to remove or by-pass the safety measures installed, thus reducing the overall safety level, IS STRICTLY FORBIDDEN.

The user shall be fully liable for any damage to objects or persons arising from the non-observance of the recommendations herein mentioned.

1.4.3. Warning about Residual Risks

Notwithstanding all the safety measures taken and listed in the previous paragraph, some risks remain during installation, use and maintenance due to:

- the presence of electricity even with the agricultural machine at standstill
- the presence of potential high temperatures in the geared motors groups

In these phases it is therefore necessary to work with the utmost care following the instructions given by the manufacturer of the agricultural machine or by the system integrator, in order to avoid any dangerous situations.

The presence of these residual risks is indicated by special warning labels attached to the enclosures of the geared motor built-in drives.



It indicates the need to pay due attention to avoid the risk of burns.

1.4.4. Warnings and Rules of Behaviour for the Operator

To avoid any dangerous conditions for the operator or damages to equipment, we advise you to scrupulously follow the warnings and the rules of behaviour listed below.



ROJ shall not be held responsible for any damage to objects and / or people occurring as a result of your failure to follow those warnings.

- Operators shall be properly trained to make best use of the equipment safely, and must have read and understood the instructions and warnings given in this manual.
- Personnel performing installation and maintenance on the machine must read this manual before performing any electrical or mechanical intervention.
- All personnel operating on the system must wear appropriate clothing, avoiding or paying due attention in case of:
 - fluttering clothes
 - necklaces, bracelets and rings
 - wide sleeves
 - long hair
 - dangling ties or scarves
- Before using the machine equipped with the PCS 150 kit, make sure that any dangerous safety conditions have been properly eliminated, that all guards or other protections are properly installed and that all safety devices are efficient.
- Do not start the machine in case of anomalies.



DO NOT attempt to remove or by-pass any the safety measures: doing so will reduce the safety level of the system.

DO NOT perform any type of work with the machine powered up.



At the end of every maintenance work, ensure that no used tool remained near the geared motors.



Prior to the machine startup, restore and always check the correct functioning of the safety devices, if they have been de-activated during the operation.



After any operation on the equipment all materials having an impact on the environment (such as, for example, electrical cables, components, etc.) must be properly disposed of in accordance with the applicable regulations.

1.4.5. Noise level emitted

The PCS 150 system has been designed and built in such a way as to minimize the noise level emitted during its normal operation.

In any case, since the only sources of potential noise introduced by the PCS 150 system (*geared motors*) are of negligible magnitude (<70 dBA) relative to noise produced by the agricultural machine as a whole, the responsibility to determine the A-weighted sound pressure level generated by the whole machine lies with the manufacturer of the machine itself and/or the end user.

1.4.6. Proper and Improper Use

The PCS 150 system is designed to be incorporated into transplanters.

The use of the PCS 150 for different purposes may result in damage to Persons or the equipment itself and is therefore considered as an **improper use** which the Manufacturer is not held responsible for.

1.4.7. Reliability of the safety-related control systems

In the above machine, the safety-related control systems should be designed (*by the seeder manufacturer or the system integrator*) in accordance with the principles of Harmonized Standard EN ISO 13849-1:2015. The Category and implemented Performance Level (PL) values (*as compared to the Required Performance Level (PLr) deriving from the Risk assessment*) should be as follows:

Safety function	Category	PLr	PL
Inhibition of hazardous movements in case of open guard of the metering unit	≥1	C	C

The PLr has been calculated using the "SISTEMA" (IFA) software.

The calculation of the implemented PL shall be carried out and recorded by the seeder manufacturer of the system integrator.

2. INSTALLATION

2.1. FEATURES OF THE DMD0 e DMD2 (MD) GEARED MOTORS

For further information, please refer to the following enclosed documents for the DMD0:

- *TD_1406.601_revD.pdf or later revision.*
- *1061_hard.pdf*
- *1061-cid-a.pdf*
- *1061_angle.pdf*

For the DMD2:

- *TD_DMD2_rev1.pdf o later review.*

2.2. GEARED MOTOR (MD) INSTALLATION

2.2.1. General principles

The fastening of motors to the machine, whether they are used for the rotation of the transplanting element or the fertilizer/micro-granular distributor shaft, must be carried out in a way as to ensure a perfectly aligned coupling between the disk/distributor shaft and the reducer outlet hollow shaft.



In the absence of a perfect alignment, radial forces may occur on the bearings, causing an increase of the necessary torques and a reduction of the device life.

In order to relieve tension on the bearings, it is possible to use rubber bushes supplied with the motor and / or an elastic joint. This one is not supplied with the motor kit and it must be chosen and dimensioned according to the application.

For the DMD2 it is recommended to secure the motor with the cable pointing downwards.

To avoid tearing the motor cable, it is recommended to secure it with a clamp on a rigid surface approximately 30 cm from the motor connector.

2.3. DMD0

2.3.1. Outlet shaft torque and speed

The following features refer to the geared motor outlet shaft (slow shaft) magnitudes.

Nominal torque	8.75Nm
Peak torque	19Nm (single pulse, duration 500ms) 12Nm (repetitive, duration 500ms, every 5 second)
Nominal speed	100 rpm

The torque and speed of the application must comply with the above requirements.

For more information, please refer to *TD_1406.601_revD.pdf* or later revision.

2.3.2. Outlet shaft dimensions

The geared motor outlet has got a hollow shaft with the following characteristics.

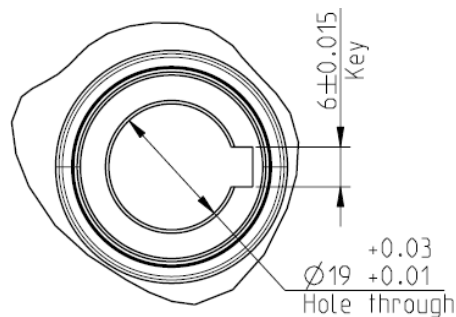

Picture 2-1 Outlet shaft dimensions

For further information, make reference to the file *1061-cid-a.pdf*

2.3.3. Fastening flange characteristics

Please refer to *1061-cid-a.pdf*

2.3.4. Tilt limits

The gearbox should work with the axis parallel to the horizontal one.

In order to grant a suitable lubrication of the reduction phase, it is necessary not to exceed the maximum tilting indicated below.

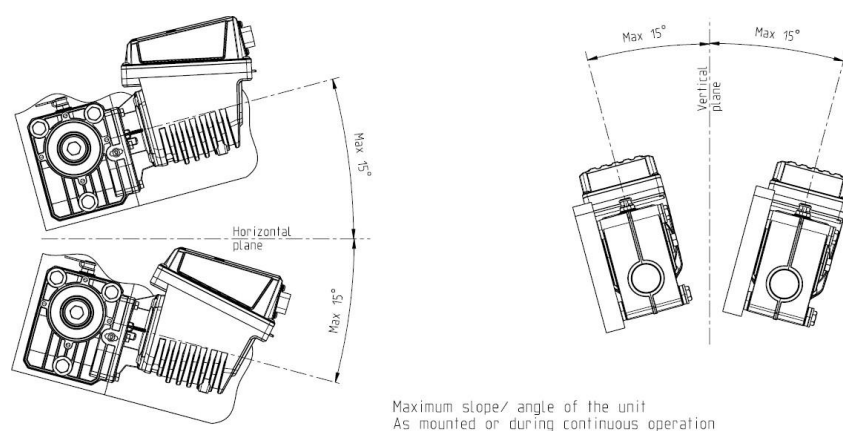

Picture 2-2 Tilt limits

For more information, please refer to [1061-angle.pdf](#)

2.3.5. Transport cap

The motor is delivered with the oil filling cap, with the rubber part positioned, in order to avoid lubricant leakages during the transport stage. This part is exclusively mounted for transport purposes and should be removed during installation.

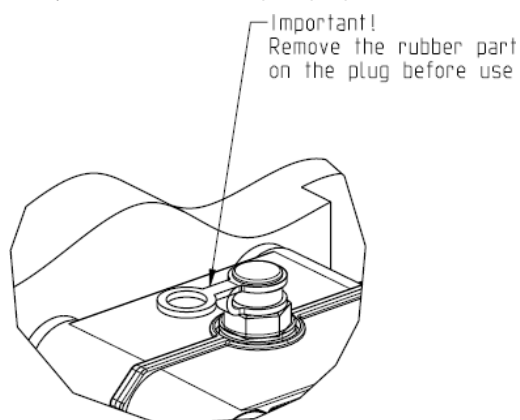

Picture 2-3 Cap with vent

2.3.6. Fastening

For a correct fastening of the geared motors 6 special aluminium bushings have been provided.

The motor must be fastened to the flange, using bushings, M8x80 bolts and standard M8 washers, as indicated on the following picture.

We suggest locking the bolts with a thread locker.

Tightening torque: 10 Nm.

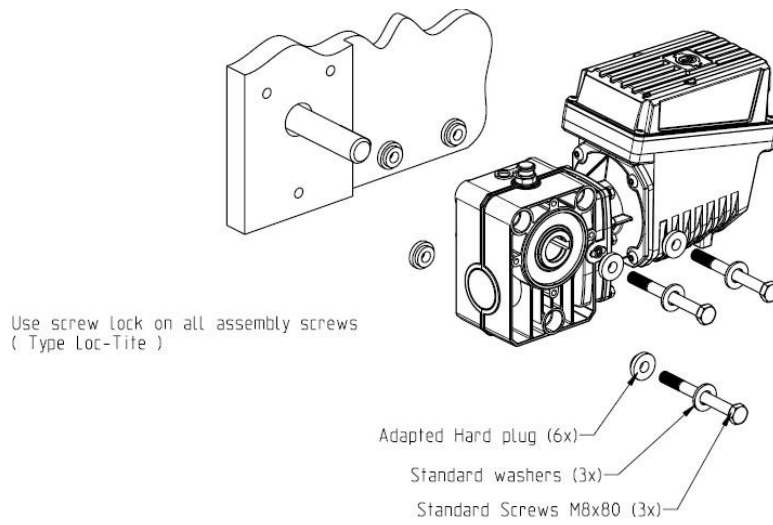

Picture 2-4 Particulars for the geared motor fastening

2.4. DMD2

2.4.1. Outlet shaft torque, speed and axial/radial loads

The following features refer to the geared motor outlet shaft (slow shaft) magnitudes. Designed for 12V agricultural equipment

- 4,5 Nm, 80 rpm @ outlet shaft (54T01185)
- Built-in driver for the brushless motor
- 2 digital inputs
- Axial load allowed: 100N
- Radial load allowed: 200N

2.4.2. Overall dimensions of the geared motor and dimensions of the outlet shaft

The geared motor outlet has got a shaft aligned with the fast shaft of the electric motor. The dimensions are shown in the technical drawing below.

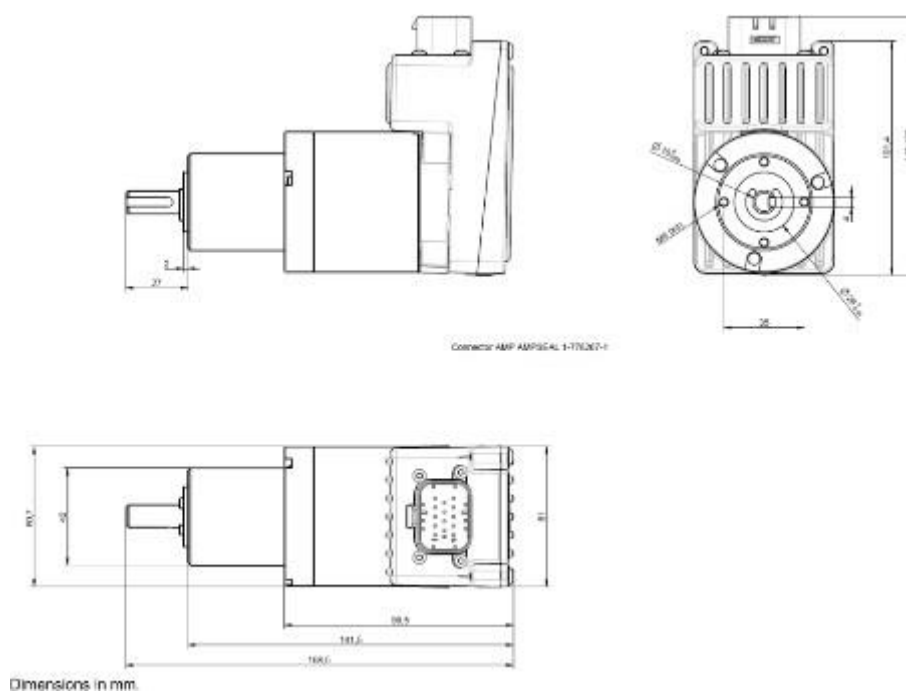

Picture 2-5 Outlet shaft dimensions

For further information please refer to *TD_DMD2_rev1* or later review.

2.4.3. Fixing flange features and geared motor fastening

This kind of geared motors can be easily fastened by fixing the reduction gear in the desired position. The fixing flange must be suited to bear an approx. weight of 1,5 Kg and 4 M4 screws are needed.

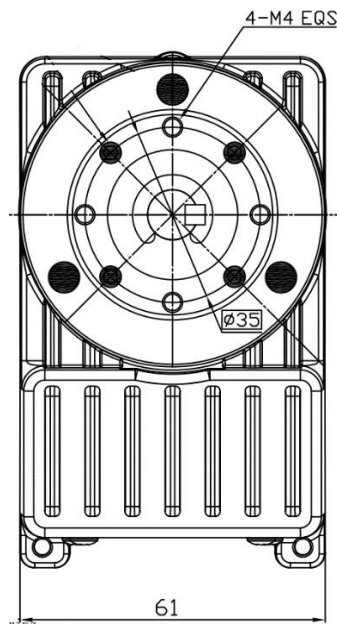

Picture 2-6 Particulars for the geared motor fastening

2.5. ALTERNATOR

The alternator is used to create a supply source independent from the tractor's one.

The machine manufacturer should provide FOR the mechanical solution to fasten the alternator and connect it by means of a suitable transmission belt and an overdrive, from the tractor PTO.

For machine configurations up to 12 rows we suggest an Iskra alternator type AAN 150A 14V. Nominal current 150A.

(Reference drawing: ott_11204254_50034_pre_aan8166_14v_150a_mtz.pdf)

2.5.1. Pulleys and rotation direction

The pulleys (PTO and alternator side) should be chosen in order to reach a speed of 3000 rpm, at the PTO nominal speed.



The shaft should rotate clockwise when observing the pulley front side from the alternator.

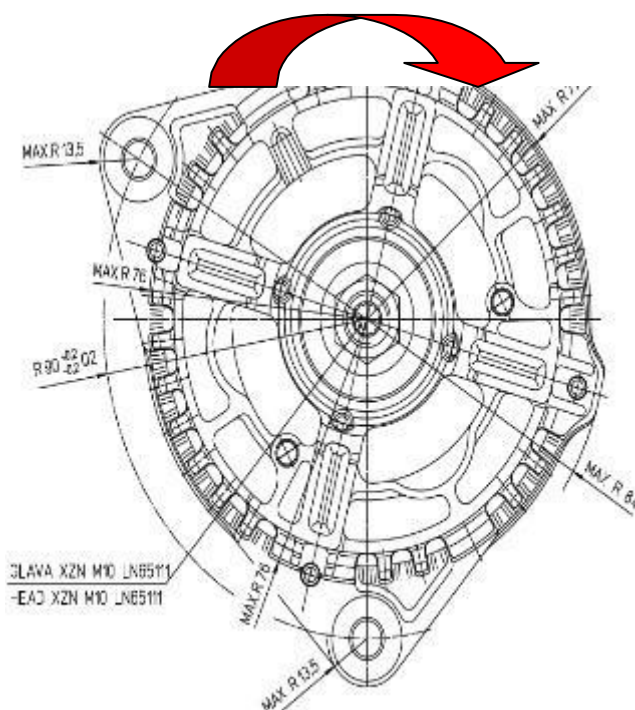

Picture 2-7 Rotation direction of the alternator

2.5.2. Absorbed mechanical power and radial loads

At this speed the absorption rate can be approx. 4kW in the worst case (= cold alternator) (Po[kW] cold curve).

2 INSTALLATION

The belt and its tensioning should be sized according to the given power.

The tensioning system is typically obtained using one of the two fastening elements as a pin and the other one as a moving element to adjust the chain tensioning.

The radial loads created by the belt on the alternator shaft, should be checked with the alternators manufacturer.

A reference value not to be exceeded in order to grant the requested lifetime is approx. 1000N.

Rotation speed of the alternator axis	3000 rpm
Rotation direction	Clockwise (see Rotation direction of the alternator)
Power required by PTO	4 kW
Radial load on the alternator axis	1000N

Table 2-1 - Main information for the alternator integration

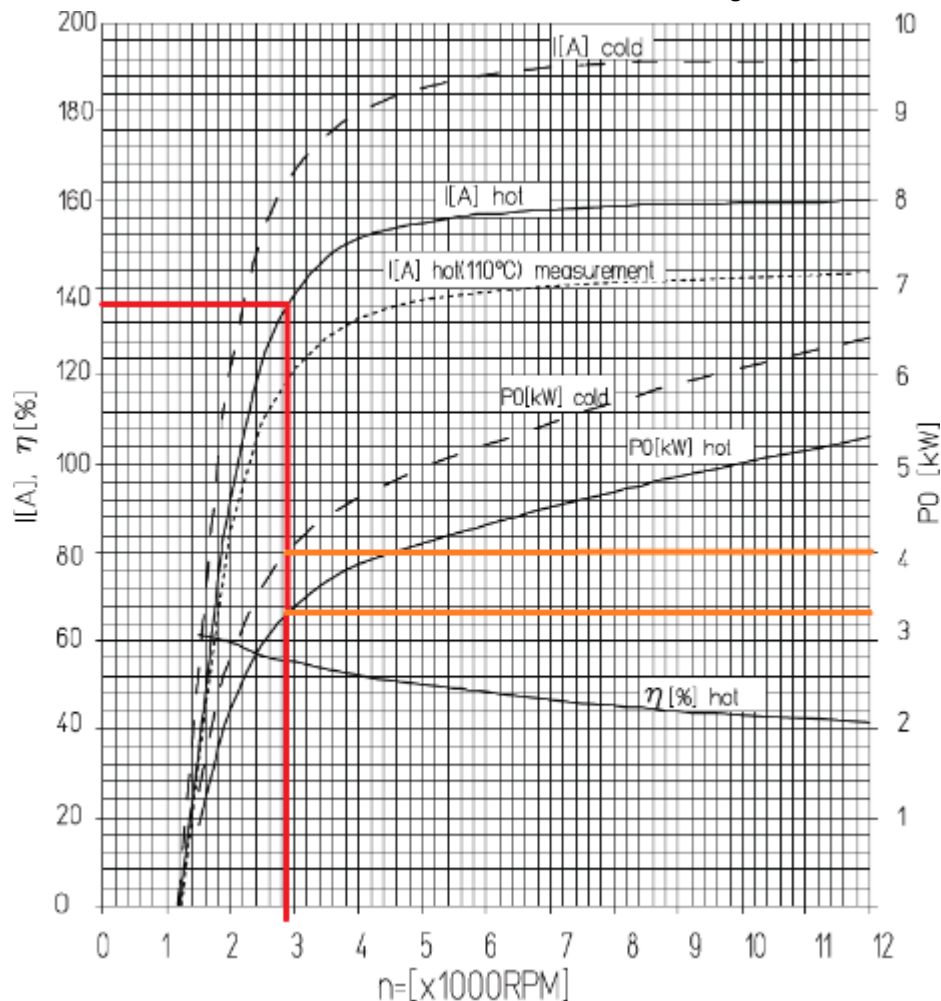

Picture 2-8 Characteristic power curves for the alternator

2.6. BATTERY

The battery should be mounted as near as possible to the alternator, within the limits imposed by its space requirements and its weight.

We suggest using a 110Ah start battery.

Battery type: FIAMM Titanium L6 110

Dimensions (LxWxH): 394 x 175 x 190 mm

Weight: 22.5 Kg.



The sizes and weights of batteries of different brands and models can vary in a considerable way. To ensure the requested flexibility when choosing the battery, provide a housing capacity of approximately 10% higher than the one indicated above.

In case you are not going to use the system for a long time, we recommend you to disconnect both battery poles in order to prevent the battery from being discharged.

2.7. SPEED SENSOR

2.7.1. Single cogwheel sensor

The speed sensor is made as a Cherry hall effect geartooth sensor GS102301 (P/N ROJ 50A00174) with cable (P/N ROJ 05R01400).

The sensor detects the speed of a toothed wheel connected to a machine drive wheel.

The sensor must be connected to the ECU cabling connector indicated by ENC-A.



Picture 2-9 Speed sensor with cable

The phonic wheel is not provided in the kit, because the maximum dimensions, the number and shape of the teeth and the connection to the wheel depend on the type of machine and on the available installation space.

The following picture represents an example of cogwheel used for the suggested sensor.

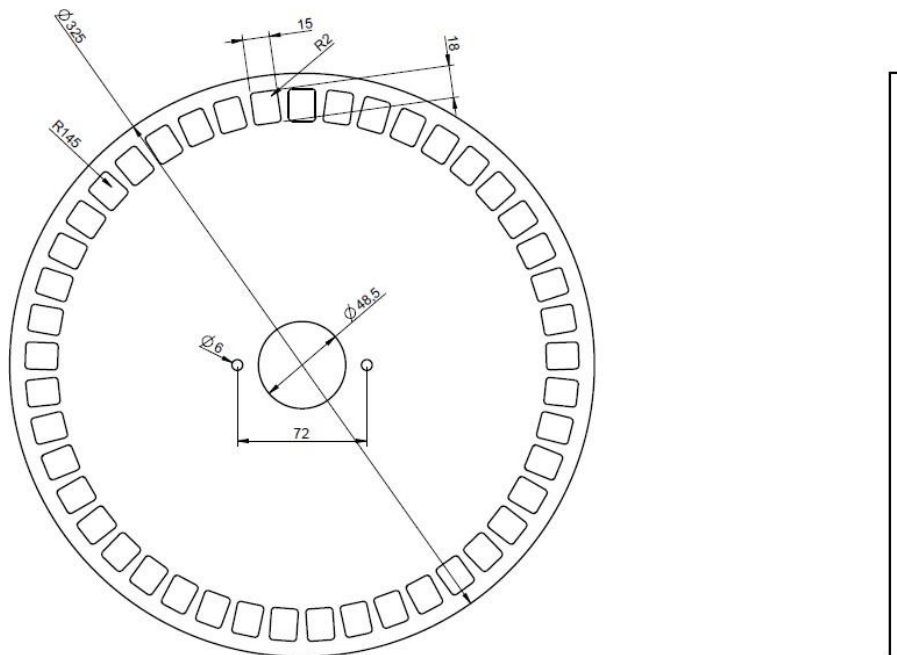





Picture 2-10 Example of cogwheel for speed sensor

The gear tooth should be fixed directly to the transplanter drive wheel, in order to avoid the need of chains and pinions.

During the installation phase, adjust the sensor/teeth distance correctly in order to ensure a precise counting.

The following procedure can be applied if you want to control the proper operation while checking the machine overall operation.

2.7.2. Wheel sensor check

- On the graphic display, select  →  →  →  and press the "Start calibration" button (see paragraph 3.6.2).
- Carry out 2 complete wheel turns and check whether the number of counted pulses is correct (for example, if the teeth number = 45, the result should be = 90).
- Press the "Cancel" button if you do not want to save the result

2.7.3. Magnetic encoder

Another option for a speed sensor is the magnetic sensor (05R01424) with corresponding magnet (50A00176). This sensor should be connected to the ECU cable using the ENC_A and ENC_B connectors.

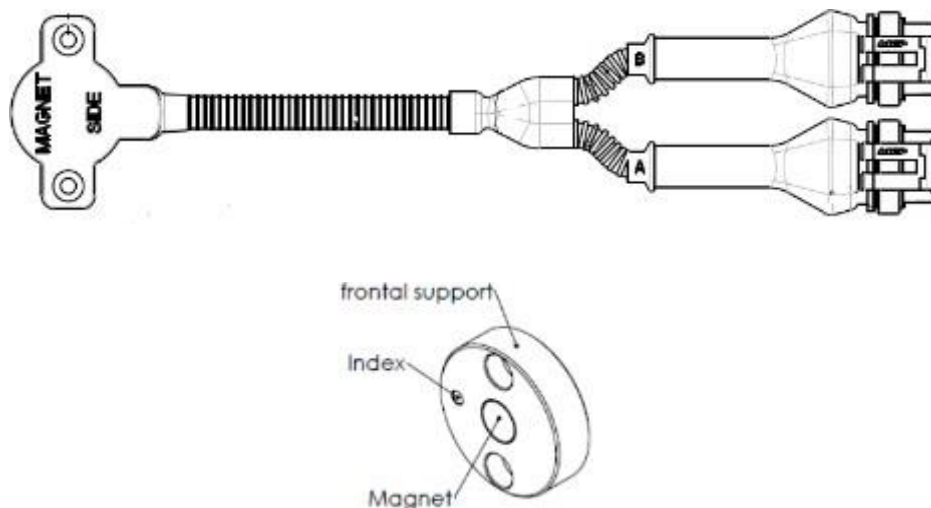



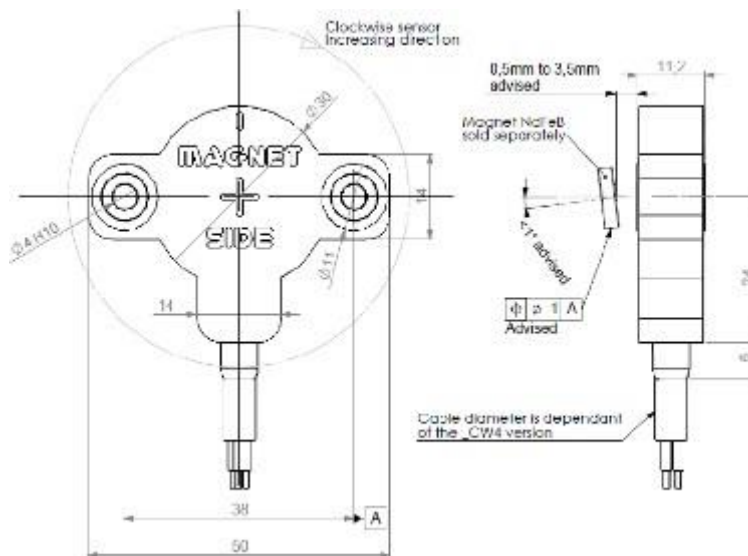

Picture 2-11 magnetic Encoder

Fasten the magnet on the wheel axle to ensure the axle is centered and maintain parallelism, as shown in Picture 2-12.





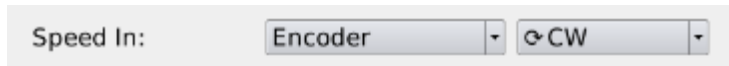

Picture 2-12 Magnetic sensor centering and alignment

2.7.4. Magnetic encoder control

- On the graphic display select  →  →  → 
- From the “Speed” menu, select “Encoder” and choose the appropriate CCW or CW direction depending on the application:



- On the graphic display select  →  →  → 
- Press the “Calibration” button (see paragraph 3.6.2).
- Let the wheel turn for a while and check that counted pulses number increases. If it's not the case, change the direction (CCW or CW).
- Press the “Cancel” button if you do not want to save the result

2.8. MACHINE POSITION SENSOR

It is a mechanical proximity sensor (P/N ROJ 05R01422) used to define whether the machine is in transplanting position (machine lowered) or in transfer position (machine raised).

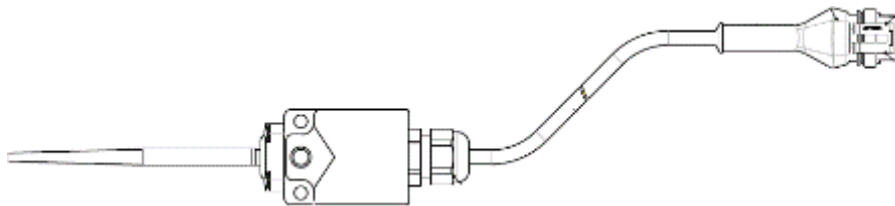

Picture 2-13 Position sensor

The sensor must be fastened to the machine frame, in a way that:

- In seeding position, when the machine is lowered, the sensor is deactivated (the rod is in rest position)
- In transfer position, i.e., when the machine is lifted, the sensor is activated

The sensor must be connected to the ECU cabling connector indicated by PROX-MACHINE.

The following procedure can be applied if you want to control that the sensor functions properly while checking the machine overall operation.

2.8.1. Position sensor check

On the graphic display main page  (see paragraph 3.7), check the tractor icon with in both conditions:

Sensor off: tractor icon indicating that the machine in working position.



Sensor on: tractor icon indicating that the machine is in taxing position.



2.9. ECU POSITIONING

The ECU housing should be preferably mounted in a sheltered position of the machine, with the cables outlet facing downwards.

For a proper fixing of the signal/communication cables on the control unit, use a 1/4" wrench and tighten the cables on the relative front panel.



Cable output

Picture 2-14 ECU positioning



Both connectors should be plugged to the front panel in order to avoid water and dust penetration, even if in some configurations the 30 poles connectors could not be used.

In this case you can use the 30 poles ECU plug (P/N ROJ 05R01334) or a cable already fitted for the test and pressure sensor button (P/N ROJ 05R01380).

2.10. SDB POSITIONING

The SDB (sub distribution board) should be mounted on a sheltered position and central to the machine, in order to make the cables routing easier.

2.11. WIRING DIAGRAM

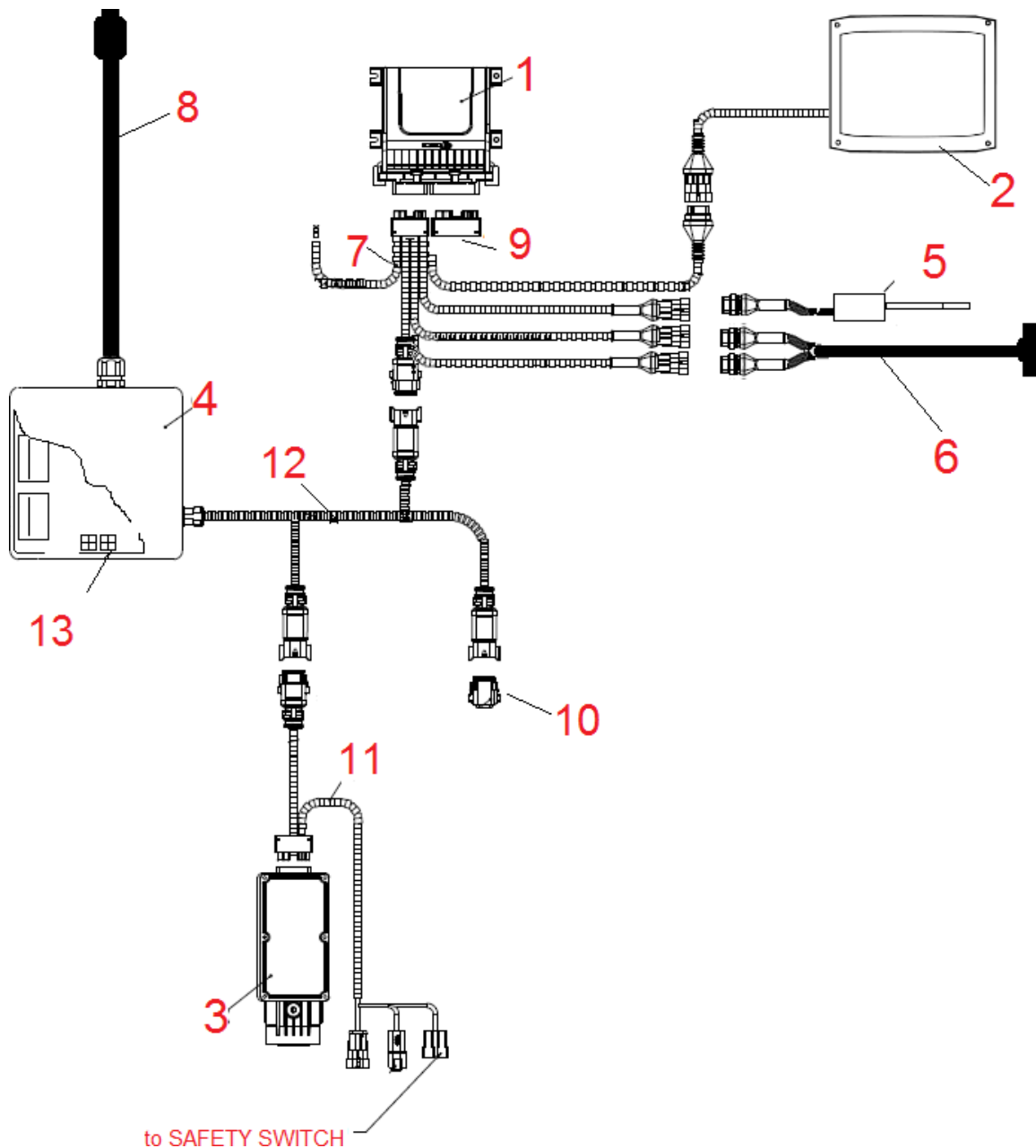

Picture 2-15 Wiring diagram of the system

2.11.1. Main components

Code	Description	Ref. on wiring diagram
54T01068	PCS 150 ECU	1
58G00074	AGRIMATE GRAPHICAL CONSOLE	2
1406.601	DMD 0	3
56C00646	PCS SDB 12+12	4
56C00651	PCS SDB 3 + 3	

2.11.2. Connection ECU

Code	Description	Ref. on wiring diagram
05R01422	MECHANICAL SWITCH SENSOR	5
50A00176	MAGNET M9105/F26 FOR 05R01424	6
05R01424	MAGNETIC ENCODER HCW4	
05R01379	ECU 18P CABLE DEMETER	7
05R01334	ECU PLUG 30C	9

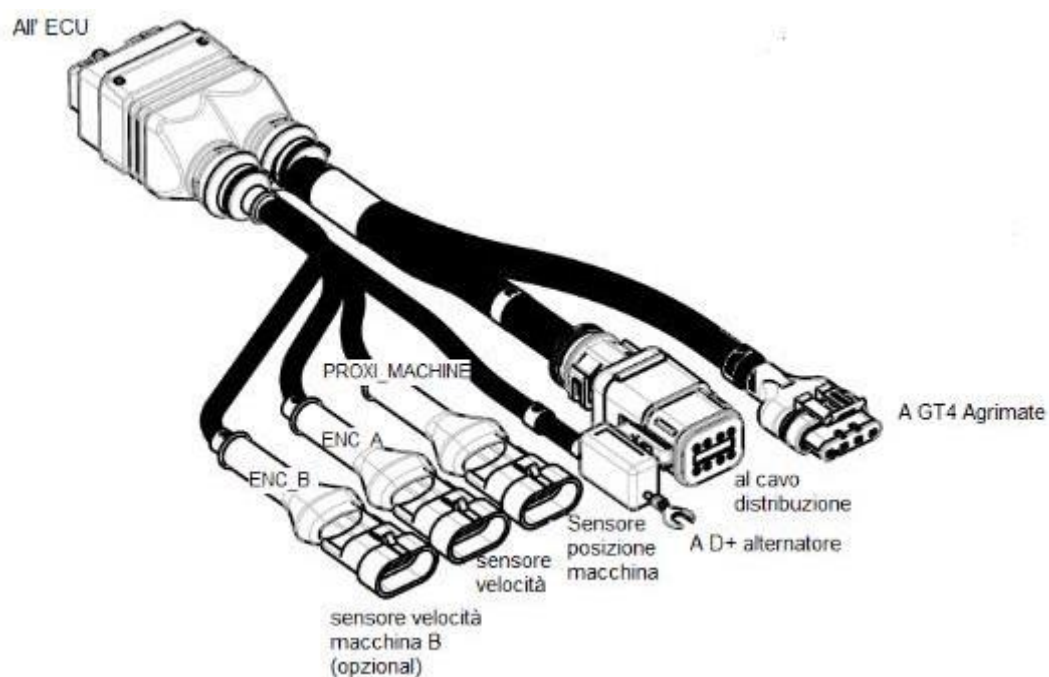

Picture 2-16 ECU wiring diagram

2.11.3. SDB and power supply cables connection

The Picture 2-17 and Picture 2-18 show how the connections on the two versions of the board included in the SDBs are made, respectively the SDB 12+12 (56C00646) and the SDB 3+3 (56C00651).

The boards are divided into two or four dials indicated by the letters TL1, TR, BL, BR corresponding to two or four cable lead-through on the SDB junction boxes.

- The red conductors (positive) of the 05R01372 and/or 05R01373 cables should be connected to the spring terminals of the corresponding dial.
- The black conductors (negative) of the 05R01372 and/or 05R01373 cabling should be connected to the spring terminals in the area indicated by the black rectangle shown in the following figure ("Negative").

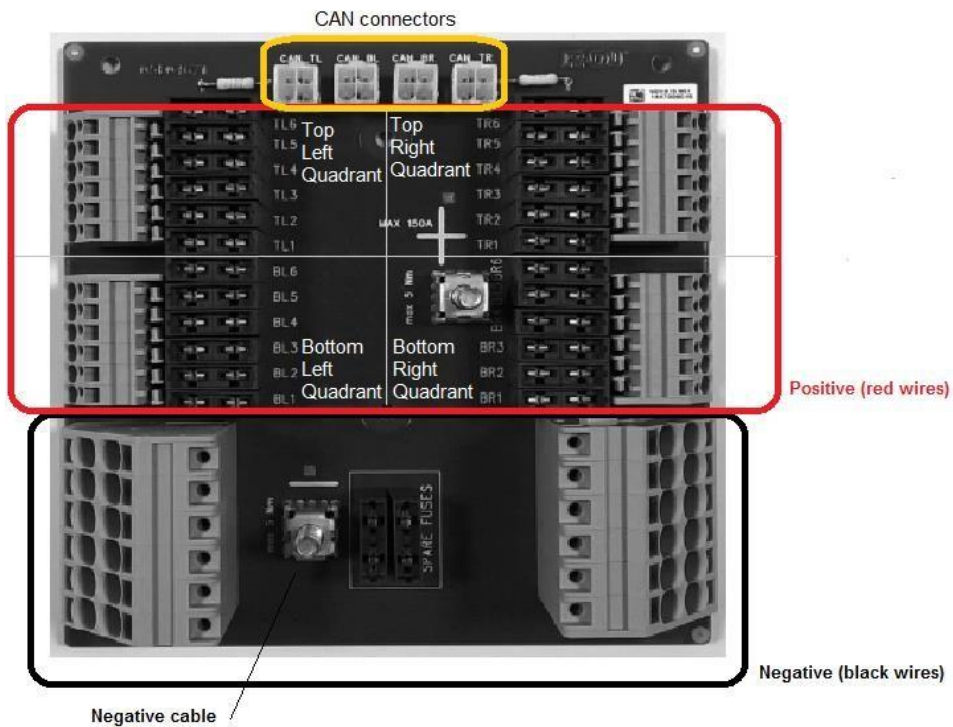

Picture 2-17 SDB 12+12 connections

¹ These are acronyms for Top Left, Top Right, Bottom Left, Bottom Right respectively

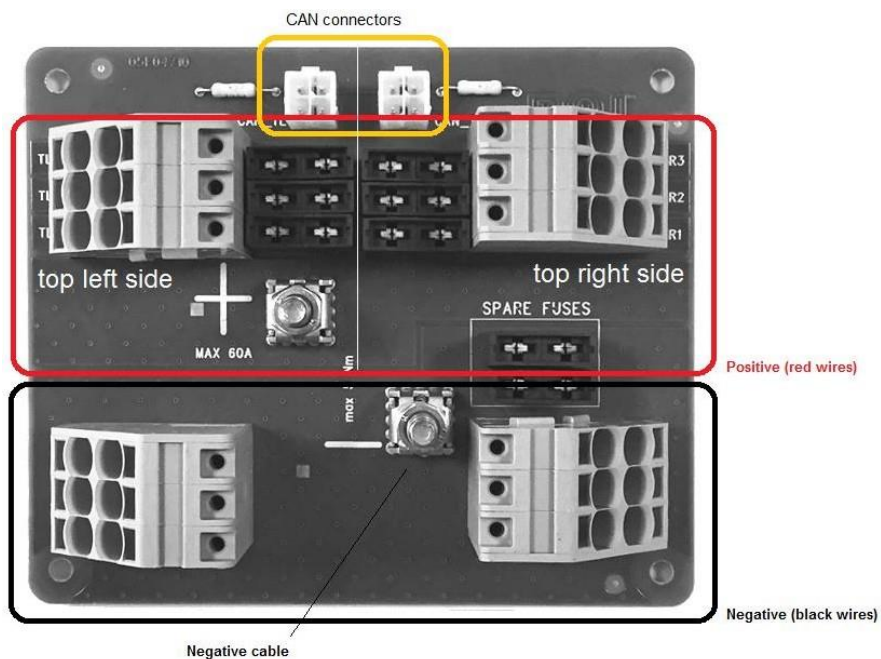

Picture 2-18 SDB 3+3 connections

Code	Description	Ref. on wiring diagram
05R01411	SDB - ISO12369 CABLE	8
05R01404	DMD DISTRIBUTION CABLE 3 POS	12
05R01372	DMD DISTRIBUTION CABLE 6 POS	
05R01373	DMD DISTRIBUTION CABLE 7 POS	
05R01385	CAN TERMINATION (MOLEX) SDB	13

2 INSTALLATION

The following Figure shows the correspondence between the number of fittings and the number printed on the red corresponding conductor.

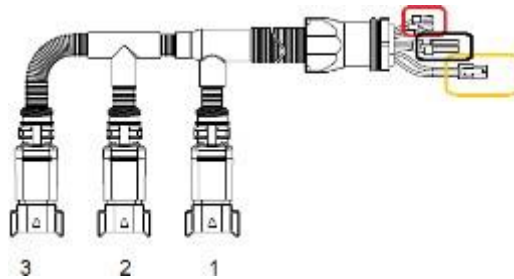

Picture 2-19 05R01404 cable – 3 outputs

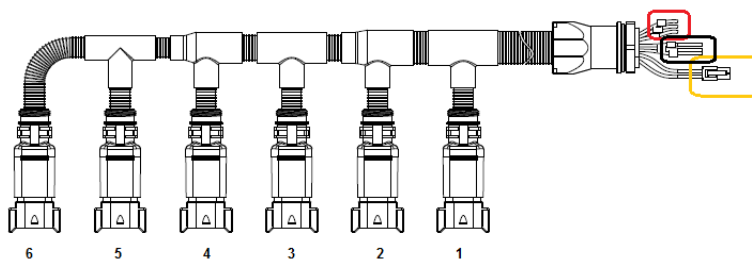

Picture 2-20 - 05R01372 cable – 6 outputs

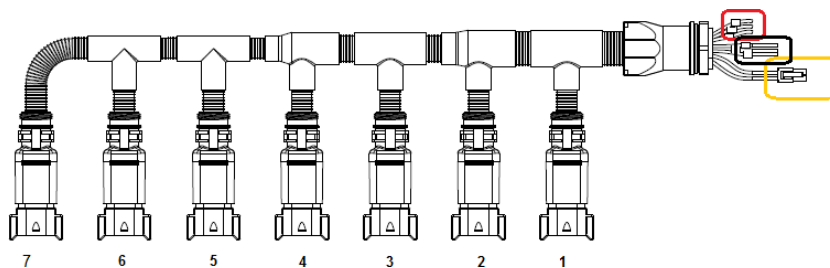

Picture 2-21 - 05R01373 cable – 7 outputs



The CAN connector (4-poles white Molex) should be connected to the CAN socket corresponding to the dial. (Yellow rectangle in Picture 2-17 and Picture 2-18).

The unused sockets on the distribution cables should be secured with element no. 05R01381.

Code	Description	Ref. on wiring diagram
05R01381	CAN TERMINATION (DEUTSCH) DEMETER	10
05R01404	DMD DISTRIBUTION CABLE 3 POS	12
05R01372	DMD DISTRIBUTION CABLE 6 POS	
05R01373	DMD DISTRIBUTION CABLE 7 POS	

2.11.4. Connection MD

It is possible to connect the geared motors to the system using the cables indicated by the codes of the following table. Connect one cabling side (18-poles black CINCH connector) to the MD, and the 8-poles grey Deutsch connector has to be connected to the distribution cable (05R01404 cable – 3 outputs, 05R01372 cable – 6 outputs or 05R01373 cable – 7 outputs).

The cabling differs according to the length and type of the connector used for the seed / plant sensor.

DMD0

Code	Description	Ref. on wiring diagram
Without seed/plant sensor²		11
05R01377	DMD CABLE - DISTRIBUTOR (TE) L = 1000	
05R01384	DMD CABLE - DISTRIBUTOR (TE) L = 1300	

Code	Description	Ref. on wiring diagram
With connector for MC Elettronica sensor³		11
05R01374	DMD CABLE - SEEDER (TE) L = 1300	
05R01375	DMD CABLE - SEEDER (TE) L = 1700	
05R01376	DMD CABLE - SEEDER (TE) L = 2300	
05R01387	DMD CABLE - SEEDER (TE) L = 3500	

Table 2-2 - DMD0 cable codes

DMD2

Code	Description	Ref. on wiring diagram
Without sensor input		11
05R01474	DMD 2 CABLE - HOPPER L=1300	
05R01475	DMD 2 CABLE - SEEDER L=1700	
05R01494	DMD 2 CABLE - SEEDER L=2500	

Table 2-3 - DMD2 cable codes

² Suitable to MDs for fertilizers and microgranulators

³ Tyco Superseal 3-poles connector



The CAN on SDB (yellow rectangle in Picture 2-17 and Picture 2-18) unused sockets should be secured with the element no. 05R01385.

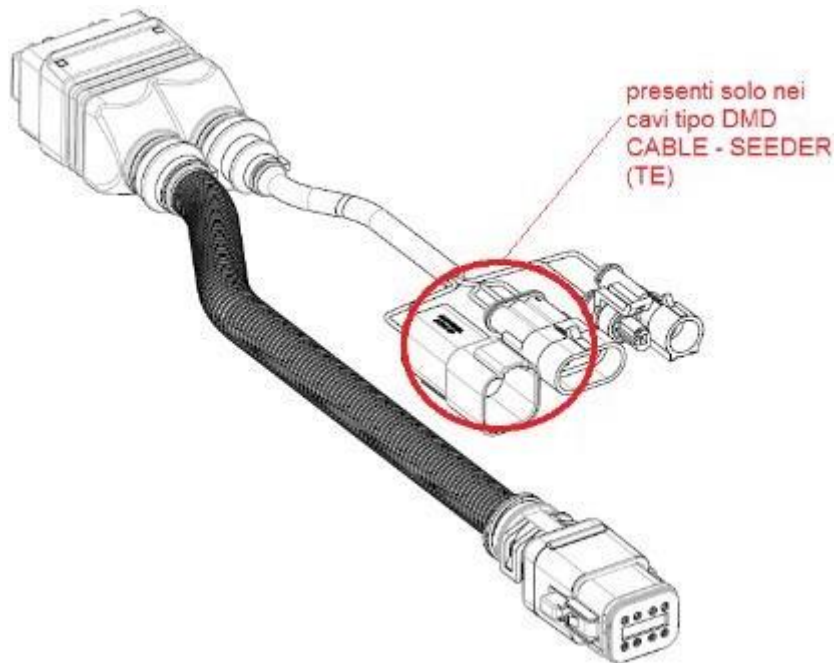

Picture 2-22 MD wiring diagram

2.11.5. Safety switch

The connection to the safety switch provides two main functions:

- **Safety function:** if the contact is open, the MD cannot rotate.
- **Addressing function:** during the MD addressing stage, the safety contact closes and confirms the device address (see paragraph 3.4.2).

The safety switch should be implemented by using:

- an electro-mechanical switch with “positive opening” NC contact (condition indicated by the symbol )
or
- an electromagnetic sensor with high reliability (e.g., SICK RE11-SA03 or equivalent)



In order to grant the required safety level (Performance Level = c – see paragraph 1.4.7), you should foresee a safety switch having the following characteristics:

- $B10d \geq 2 \times 10^6$ (see footnote below)



The safety switch is not provided with the kit, because the choice depends on the size limits of the machine on which it will be installed.

Note: B10d is the reliability parameter declared by the device Manufacturer that corresponds to the number of switching operations guaranteed without errors.

3. USER MANUAL**3.1. MACHINE START UP**

To turn on the HMI, connect the PCS 150 power supply cable to the tractor battery voltage.

Approx. 4 seconds later, the following screen appears on the HMI display.

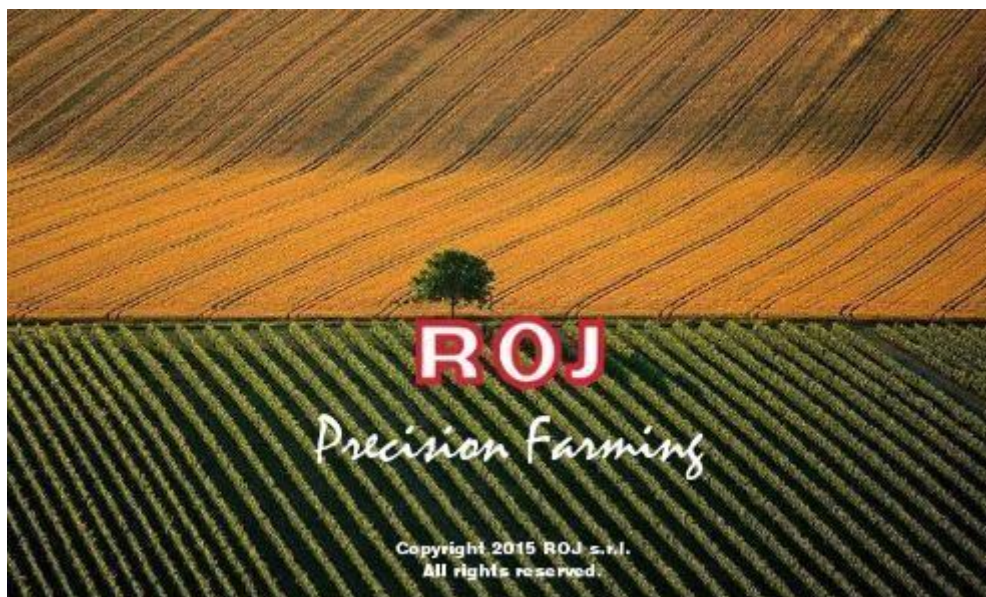

Picture 3-1 Home screen

Once the loading phase is finished, the "Home" screen indicated by the top left icon  is immediately displayed.

3.2. GRAPHIC ORGANIZATION

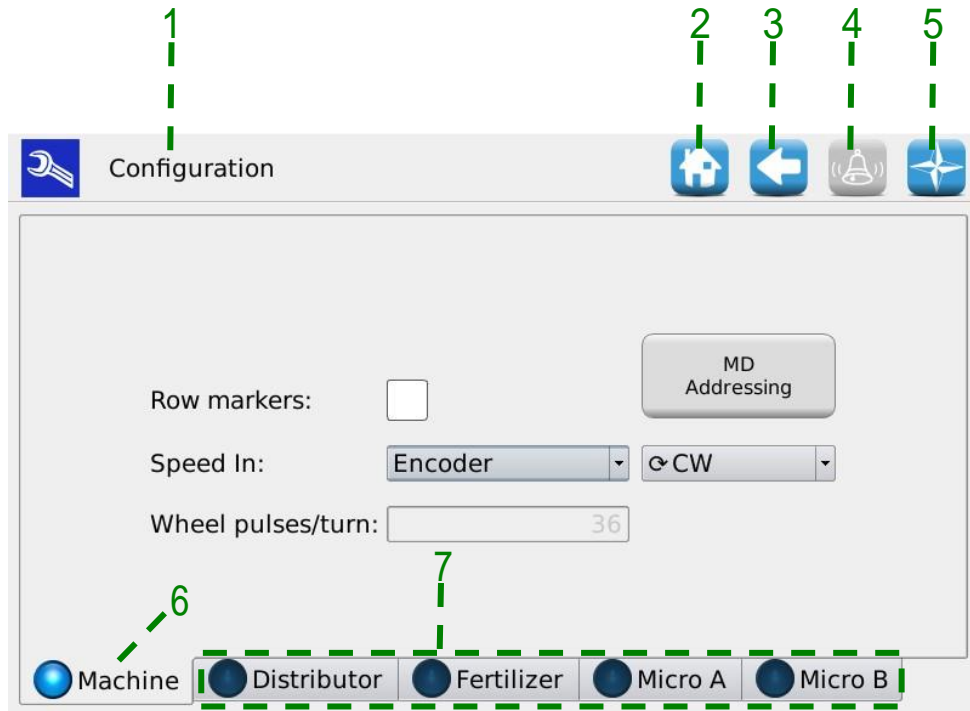

Picture 3-2 Example of graphic organization

Field	Description
1	Logo and name of the active window
2	It allows to quickly return to the home screen.
3	It allows to return to the previous screen.
4	It allows to access the active alarms window
5	It allows to access the complete console menu
6	Selected Tab
7	Non selected Tabs

3.3. ACCESS LEVELS

The access to the tabs, the buttons and the numerical fields for the setup is organized as an access levels system. Therefore, some fields can **only be modified by authorized users**.

For the PCS150 system the following access levels are foreseen, in ascending order:

Operator	It is the standard access level and does not require any password.
Manager	Not provided for use with this model.
Manufacturer Support	This access level is foreseen for the technical support service of the transplanter manufacturer. The default password is different for each manufacturer and can be changed by the manufacturer himself.
ROJ service	This access level is foreseen for the ROJ technical support.
Administrator	It is the highest access level which allows to access all system functions and is reserved to the ROJ R&D personnel.

This access level can be modified at any time, by entering the Terminal menu and clicking on the “Access” button. After this operation a window is displayed where it is possible to modify the access.

Path:

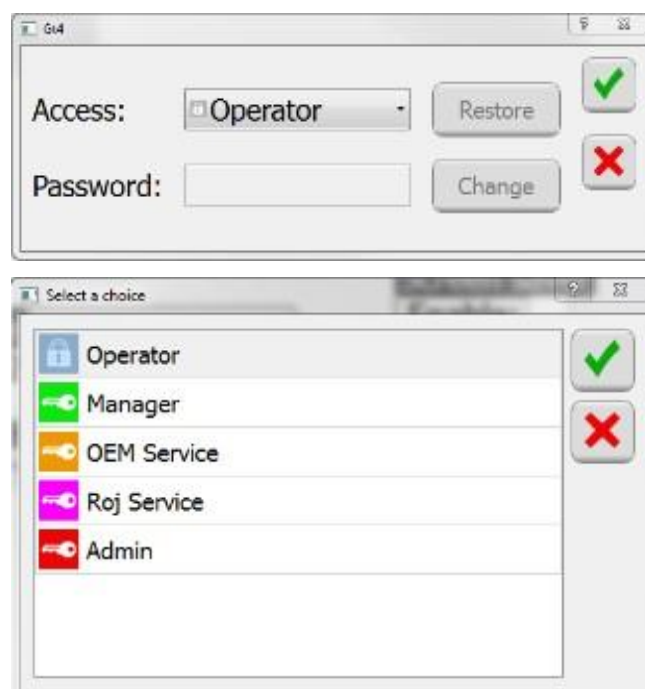

Picture 3-3 Access levels

The same window is automatically opened in case you try to access a field which is protected by a higher access level than the current active field.

3.4. MOTOR ADDRESSING

At the first installation of the machine, it is necessary to address the motors, in order to associate to the logical position (Distributor 1, Distributor 2,..., Fertilizer 1, Fertilizer 2,... Micro 1 etc.) the physical position of the motor on the machine.

The addressing procedure requires the operator's intervention and is automatically activated on the first power up of the machine.

It is also possible to force this operation, by opening the following window and clicking on the **1** button.

Path:



Machine tab

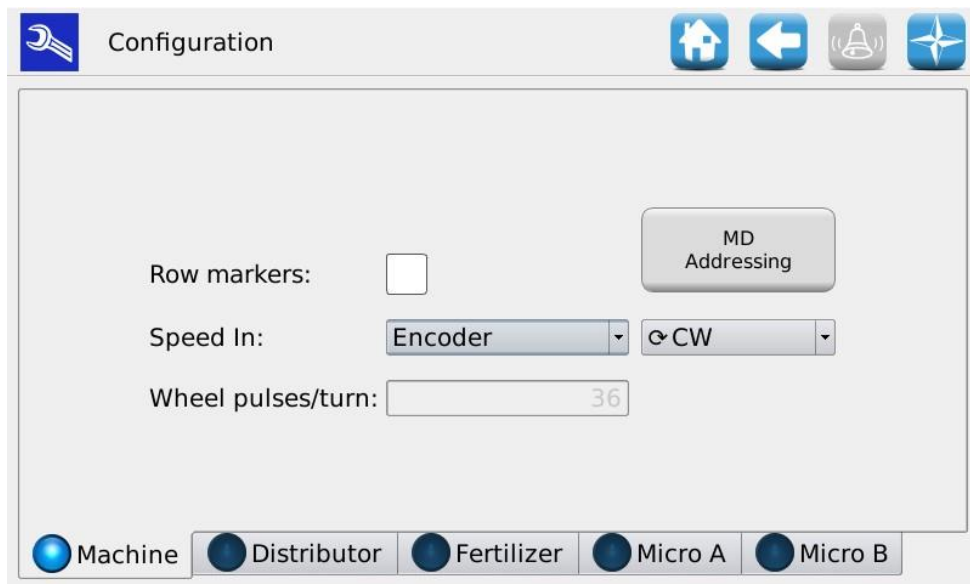

Picture 3-4 Machine Setup

Field	Description
1	Activation button for the addressing procedure

3.4.1. Machine configuration

Pushing the **1** button a machine configuration window is opened where it is possible to read the MD numbers of MDs for each distributor, Fertilizer spreaders and Microgranulators.

MD addressing window

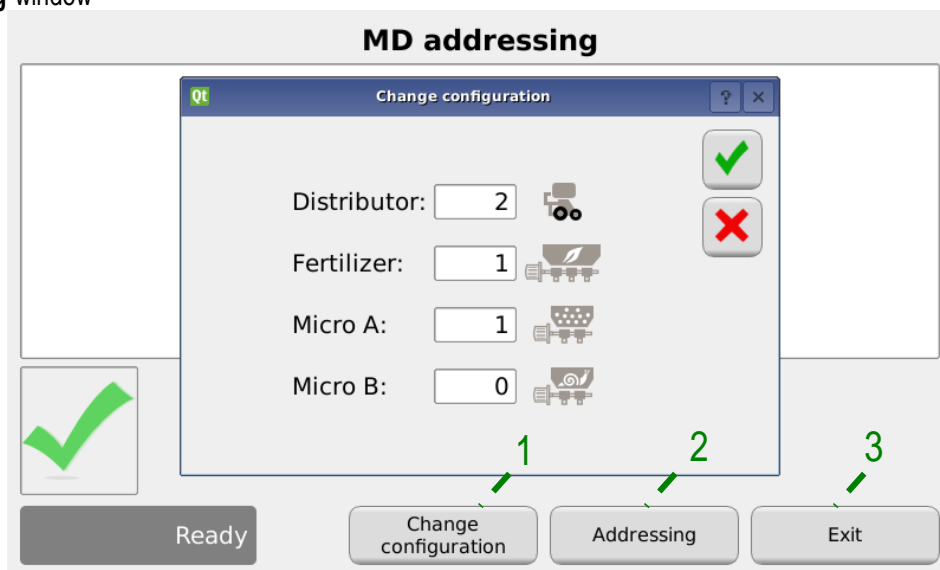

Picture 3-5 Modify configuration

Field	Description
1	It allows to modify the machine configuration
2	If this button is pressed, the real addressing session starts
3	To exit from the addressing window

3.4.2. Addressing

When the “Addressing” button is pressed, the real addressing session starts.

When the addressing sequence is active, the synoptic (summary overview) of the configuration set up on the previous phase is displayed.

MD addressing window

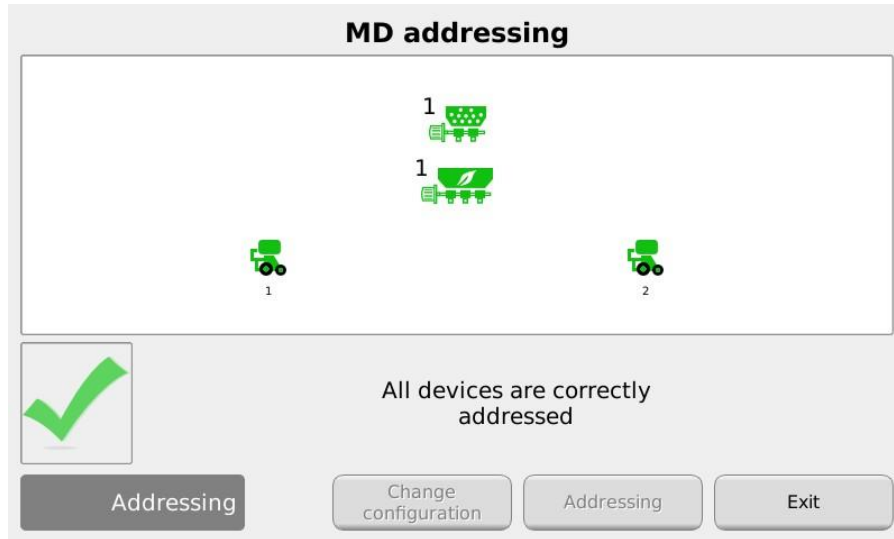

Picture 3-6 Motors addressing

Field	Description
	Motor not yet addressed
(flash.)	Motor to be addressed
	Addressed motor

Closing the protection switch (see figure) for the cable corresponding to the one flashing on the synoptic, the logic address corresponding to the flashing icon is assigned to the motor. A “beep” sound indicates that the motor has been correctly addressed and the icon turns to green.

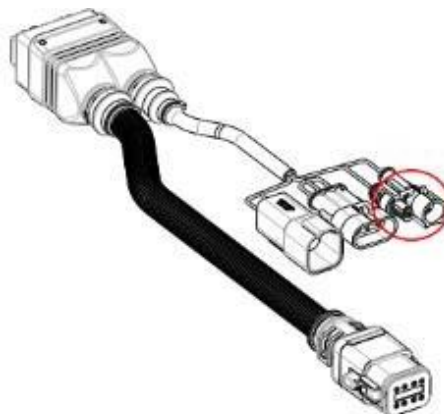



Picture 3-7 Safety switch of the motor cable

In case of error, press the motor symbol in order to display the dialog “Unaddress MD” which allows to cancel the address of one, a group or all motors:

MD addressing window



Picture 3-8 Motors Unaddressing

Field	Description
	Motor not yet addressed
 (flash.)	Motor to be addressed
	Addressed motor

If the addressing has been completed correctly, the window is displayed as shown in Picture 3-6 and it is possible to exit by pressing the “Exit” button.

3.5. MACHINE CONFIGURATION

This window allows to setup the machine during production on the manufacturer’s premises.

The setup settings of the machine can be modified only by the **Manufacturer’s Production dpt.** or by the **Technical Support.**

3.5.1. Machine tab

Path:

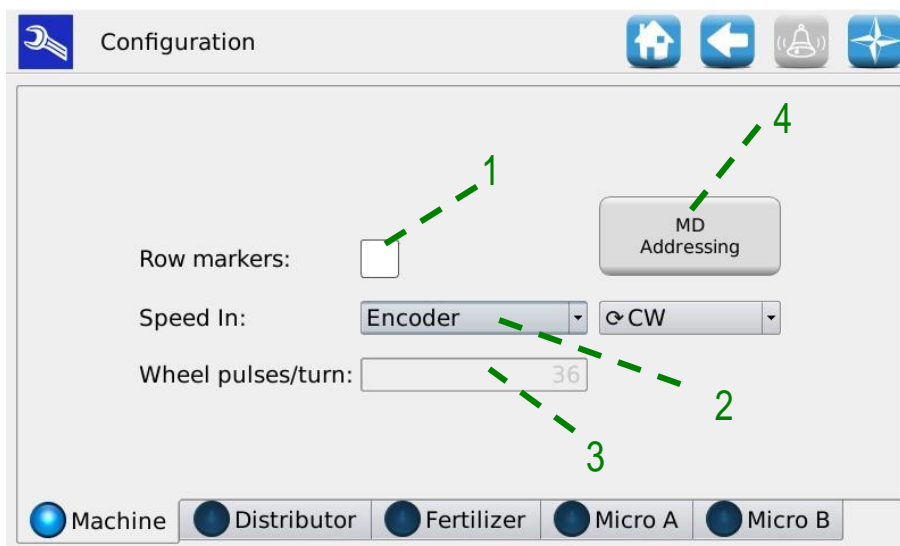

Picture 3-9 Machine Setup parameters

Field	Description
1	Enables the use of the row markers
2	It allows to select the machine speed sensor: <ul style="list-style-type: none"> - Single: Single sensor (phonic wheel) - Double: Double sensor (phonic wheel + index) - Radar - Encoder - Wheel -1 tooth: Single sensor but the phonic wheel is missing a separator/tooth. (If selected, the user is asked to turn off and restart the system from the main disconnect switch/battery disconnect switch)
3	When selecting “Double sensor” it is necessary to specify the number of teeth of the phonic wheel (number of pulses of the wheel between two index pulses)
4	It allows to force the motors addressing session
5	If “Encoder” is selected, the direction of rotation must be indicated



If you plan to work at a tractor speed lower than 4 km/h, we recommend using the encoder so that you can maintain an accurate and dynamic behavior even at low speeds.

3.5.2. Distributor tab

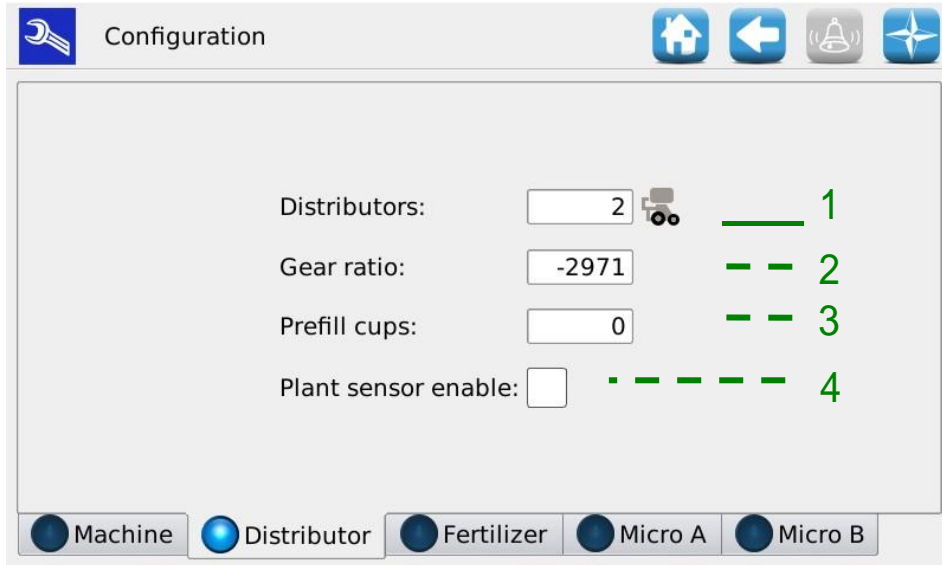

Picture 3-10 Distributor configuration parameters

Field	Values range	Description
1	1 ... 32	Number of distributors
2	-32500 ... 32500	Reduction ratio multiplied by 100 (for example: gear ratio 29,71 : 1 → 2971). The minus sign indicates the direction of rotation opposite to the standard one.
3	0 – 300	0: prefill is enabled 1 ... 300: Number of cups which should be counted to end the distributor prefill phase.
4		It enables the use of the plant counting sensor (if not installed do not enable the check mark and the theoretical number of plants will be counted)

3.5.3. Fertilizer spreader/A Microgranulator A/B Microgranulator Tab

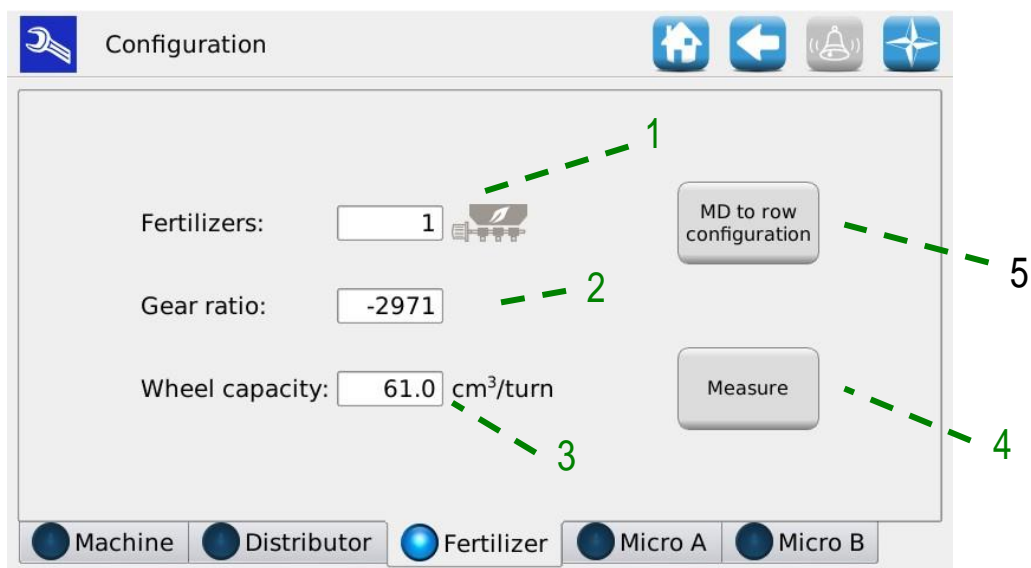

Picture 3-11 Fertilizer Spreader Configuration Parameters

Field	Values range	Description
1	0 - 8	Number of motors for the fertilizer spreader hoppers
2	-32500... 32500	Reduction gear ratio multiplied by 100 (for example: reduction ratio 29,71 : 1 → 2971) The minus sign indicates the direction of rotation opposite to the standard one. Standard values: DMD0: (-)2971, DMD2 (-)2685. Note: If an external reduction gear is fitted, the reduction ratio must be multiplied by the standard value. Ex: Chain driven gearbox, with 12 teeth gear on the DMD0 motor, and gear on the 21 teeth distributor → the value to be entered will be: $21/12 \cdot 2972 = 5201$
3	0 – 300 [cm³/turn]	The quantity of fertilizer released at each turn of the volumetric distributor shaft.
4		It allows to calculate the volume cm³ of the auger/distributor in use.
5		It allows the association of the motors corresponding to the hoppers to the motors of the rows.

3.5.4. Rows MD Configuration

If it is foreseen that one or more motors applied to fertilizer spreaders or microgranulators are used for several rows, as in the example in Picture 3-12, it is necessary to indicate such a configuration in order to correctly adjust the product metering.

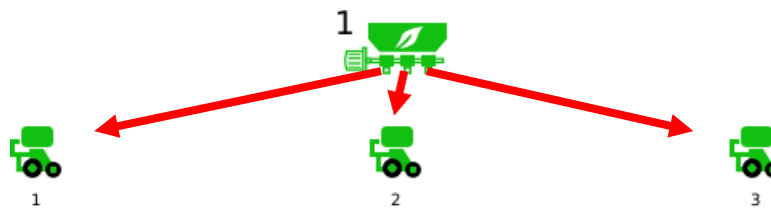

Picture 3-12 Example of a fertilizer spreader serving three rows

To carry out the Rows MD configuration:

1. In the configuration menu, select the tab of the motors to be configured: Fertilizer Spreader, A Microgranulator or B Microgranulator B.
2. Press the “Rows MD configuration” button (indicated with 5 in Picture 3-11).
3. In the displayed menu, indicate for each Fertilizer Spreader/A Microgranulator/B Microgranulator motor, how many motors each of them serves with the product (in the case of the example there is a motor on the fertilizer spreader which, by means of 3 distributors, serves three motors on the rows) and press OK.

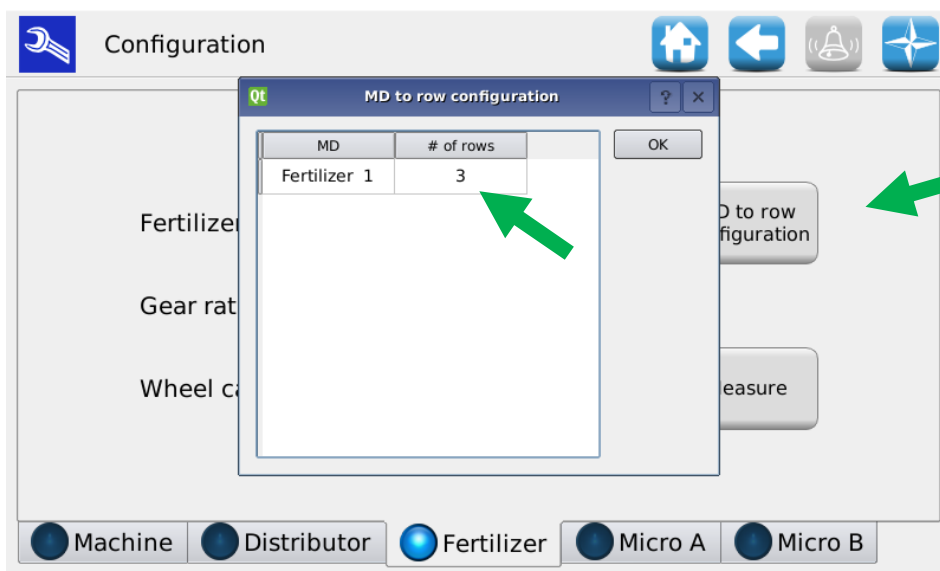

Picture 3-13 Rows MD configuration

Ex: If the machine has got 4 rows and 2 MDs for the hoppers, these can be associated as follows:

MD	# of rows
Fertiliser 1	2
Fertiliser 2	2

or

MD	# of rows
Fertiliser 1	1
Fertiliser 2	3

3.5.5. "Volume per revolution" measurement



Before performing this procedure, ensure that the "Row MD Configuration" parameters have been set correctly

Press the "Measurement" button (indicated with 4 in Picture 3-11) on the fertilizer and micro-granulator configuration page to start the wizard to experimentally calculate the amount of product that must be released from the hopper through the auger.

Fertilizer
Wheel capacity measure 1/5
 MD to Calibrate: 1
 Prefill wheel turns: 4
 Cancel Start

Fertilizer
Wheel capacity measure 2/5
 25%
 Cancel

Fertilizer
Wheel capacity measure 3/5
 Empty box before start operation
 Wheel turns: 30
 Cancel Start

Fertilizer
Wheel capacity measure 4/5
 3%
 Cancel

Fertilizer
Wheel capacity measure 5/5
 Density: 1.000 kg/cm³
 Weight: 2.0 kg
 Calculated Capacity: 22.2 cm³/turn
 Confirm Cancel

Picture 3-14 Volume per turn measurement

1. **Step 1/5** it is recommended to set a motor speed that allowing the entire product circuit to be filled.
2. **Step 3/5** place some containers to collect the product coming out of all the distributors associated with the motor under test. It is recommended to set a high number of revolutions (greater than 10) so that the measurement can be more accurate.
3. **Step 5/5** In the "Quantity" field enter the mass in kg of the total product coming out of all the distributors associated with the motor in steps 3 and 4 and the corresponding volume will be calculated automatically.
4. Finally confirm the result to load the new values obtained.



If the product density is unknown, the input value is 1 kg/dm³

The calculation formula will be as follows:

$$\text{Volume per giro [cm}^3\text{/giro]} = \frac{1000 \cdot \text{Quantità misurata[kg]}}{\text{Densità} \left[\frac{\text{kg}}{\text{cm}^3} \right] \cdot \text{Numero giri} \cdot \text{Numero distributori}}$$

For example:

- Distributor revolutions number = 10
- Weighted amount = 2,3kg
- Density = 1 kg/dm³
- Number of distributors = 4

$$\text{Volume per giro} = \frac{1000 \cdot 2,3[\text{kg}]}{1 \left[\frac{\text{kg}}{\text{cm}^3} \right] \cdot 10 \cdot 4} = 57,5 [\text{cm}^3\text{/giro}]$$

3.6. SETTINGS

3.6.1. Machine tab

This window allows to set up the transplanting parameters and the parameters for the fertilizer spreader and the A and B micro-granulators.

Path:

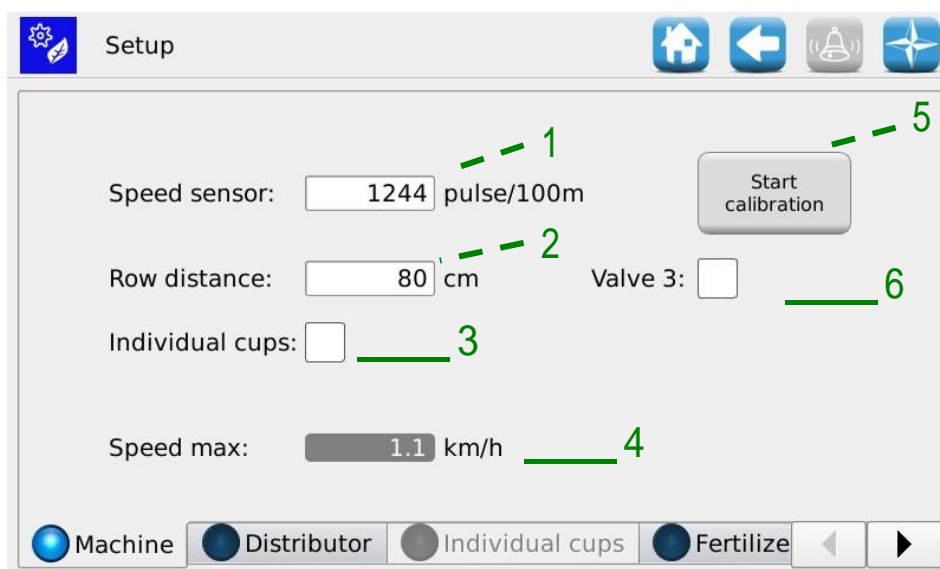

Picture 3-15 Machine settings tab

Field	Values range	Description
1	800 – 25000	Number of pulses per 100m. Press button “5” to run the speed sensor calibration session. (See below)
2	20 – 100 [cm]	Distance of two close rows in the machine.
3	On/Off	If enabled, the number of cups must be specified for each distributor. It is useful in case there are distributors with different numbers of cups and/or a different distance among plants
4	0 -16 [km/h]	It shows the maximum transplanting speed allowed with the actual settings.
5		To start the pulses/100m calibration procedure
6	On/Off	It enables the sprayer mode and activates the relay which controls the weeding pump. Available over 0,5 km/h.

3.6.2. Speed sensor calibration

Pressing button 5 in Picture 3-15, it is possible to access the sensor calibration screen.

The following window is displayed:

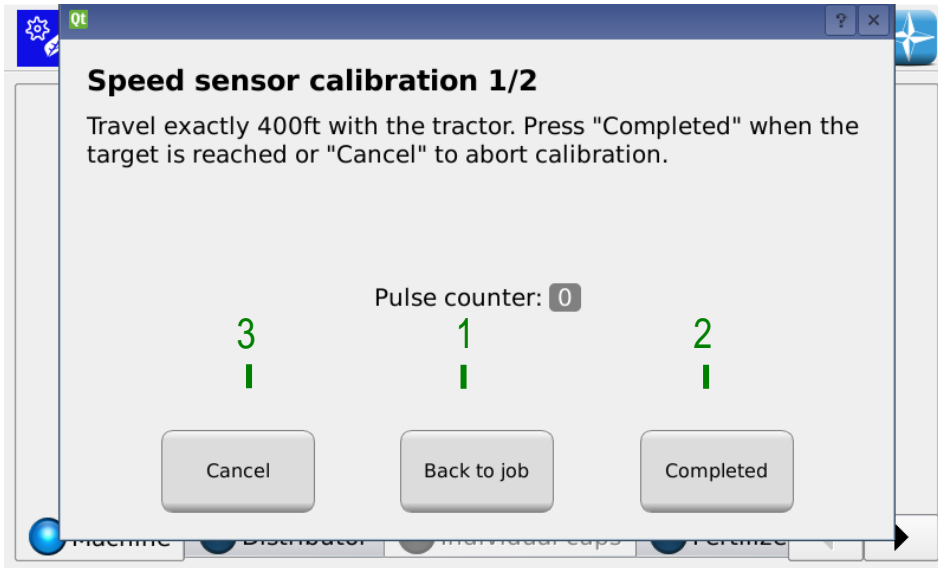

Picture 3-16 Speed sensor calibration

In order to calibrate the sensor, you need to trace a target line exactly 100m far from the actual tractor position, and to travel this 100m section at a moderate speed (5-9 km/h).

The monitor shows the wheel pulses number count, click button 2 in Picture 3-16 to accept the setting.

The sensor can be calibrated during the transplanting job

You can continue working with the settings that are already valid while covering the distance of 100 m.

Press button 3 of Picture 3-16 to return to the home page. After travelling the 100m it is possible to return to the calibration screen by simply pressing button 2 of Picture 3-16.

Note: in order to improve the precision of the absolute value for the transplanting distance, it is important to calibrate the sensor each time you change the field or if the soil conditions have changed, in order to compensate a different sinking of the tractor wheel.

3.6.3. Distributor tab



Picture 3-17 Distributor settings:

Field	Values range	Description
1	3 – 101	Number of cups for each distributor
2	2 – 100 cm	Transplanting distance expressed in cm
3	0 – 16 km/h	Maximum speed limitation imposed by the distributors settings and the maximum number of plants per minute restriction parameter (4). Warning! This is not necessarily the most binding limitation: it is possible that the fertilizer spreaders and/or microgranulators settings impose stricter limitations to the maximum transplanting speed.
4	1 – ... plants/min	Speed limitation according to the speed at which the plants are loaded onto the cups by the operator.
5		Not implemented for this application.
6	1-32	Number of active rows for job calculation.
7	Off/Auto	Off: the rows that have been disabled from the synoptic remain off until they are manually enabled Auto: the rows that have been disabled from the from synoptic are automatically enabled. This operation is done during the transition phase between lifted/lowered machine.

If the Individual cups function (indicated with 3 in Picture 3-15) in the Distributor Tab (Picture 3-17) is enabled, the Cups and Distance fields will be deactivated and it is necessary to access the Individual cup Tab (Picture 3-18) to enter the number of cups and the plant deposition distance for each distributor.



Picture 3-18 Individual cups

3.6.4. Fertilizer spreader/A Microgranulator A/B Microgranulator Tab

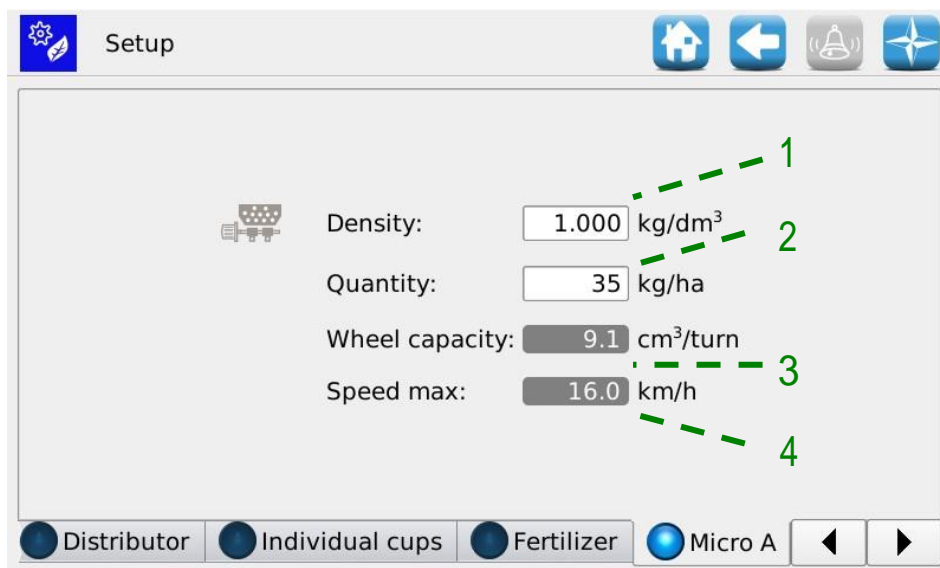

Picture 3-19 Fertilizer spreader Settings:

Field	Values range	Description
1	0,5 – 2 kg/dm ³	Density of the used product
2	50 –500 kg/ha	Quantity of product used for each hectare
3	0 – 1000 cm ³ /turn	Auger/distributor dimension in cm ³ .
4	0 – 16 km/h	Maximum speed limit imposed only by the only fertilizer spreaders settings. Warning! This is not necessarily the most binding limitation: it is possible that the other settings impose stricter limitations to the maximum transplanting speed.



3.7. HOME PAGE

This screen offers a general overview of the system functions and allows to:

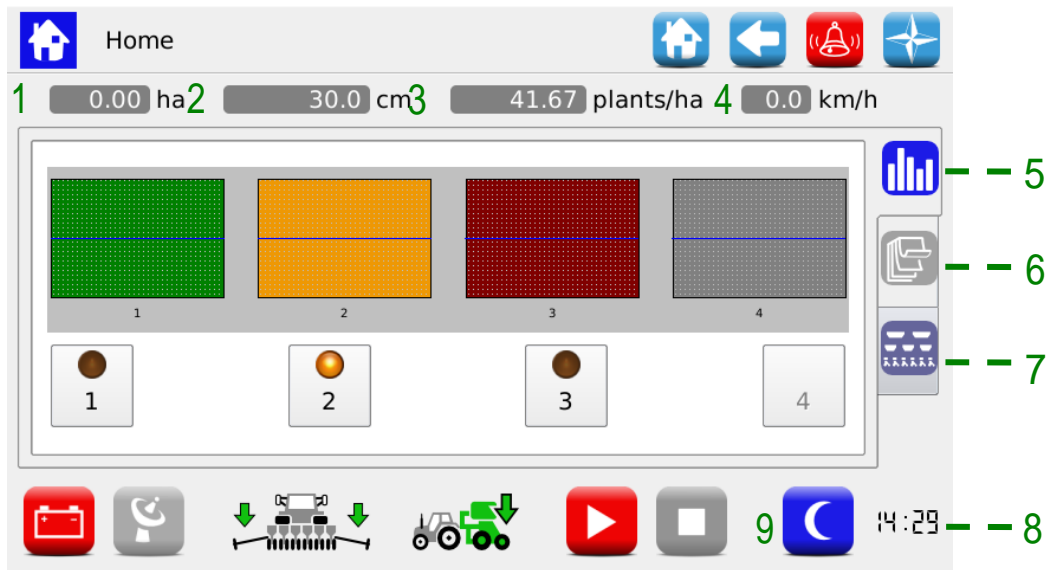







- start, finish and temporarily suspend the transplanting activity.
- get a graphical indication of the machine position (lifted/lowered), the battery and alternator status and the row markers position.
- have a graphical indication of the job
- easily access the rows switching off function.

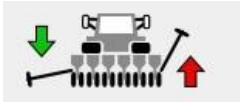

Picture 3-20 Parts Homepage

Field	Values range	Description
1	Value in ha	It shows the partial ha-counter, in relation to the actual or just finished job.
2	Value in cm	Average transplanting distance
3	Value in plants/ha	Average investment
4	Value in km/h	Here you can see the real time system speed, as detected by the set speed sensor.
5		Row exclusion Tab
6		Summary information Tab
7		Synoptic Tab
8	h:min	It shows the set time
9		Button for the day/night backlight activation.  It activates the backlight set for the night  It activates the backlight set for the day

The backlight settings can be changed via the Terminal menu (see chapter 3.11).

Field	Function	Description
	How to use the alternator	<p>The system is working in battery mode. The alternator is not charging the battery or the PTO has not been activated.</p> <p>press the battery icon to activate an alternator power up cycle.</p> <p>The system is working using the battery and the alternator.</p>
	Row markers	<p>It shows the row markers status.</p> <p>This icon is updated in real time</p>
	Machine status	<p> Machine lifted</p> <p> Machine lowered</p>
	Job indicators	<p> Active job</p> <p> Inactive job</p> <p> Job paused</p>



When the transplanting job is active, the motor output shaft and the connected transmissions will rotate according to the movement of the machine, as detected by the speed sensor.





In case it is necessary to perform any operations on the transplanting system, to access the fertilizer spreader and micro-granulators auger, the system should be disconnected from power supply via the battery disconnect switch before removing or opening the guards.

3.7.1. Row management

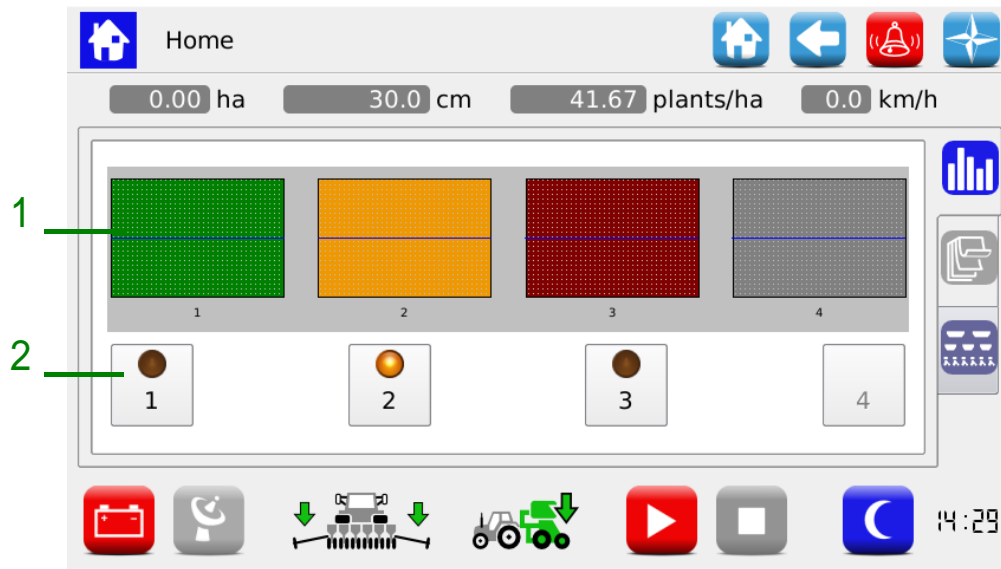
Here you can easily view the status of the distributors and deactivate the rows.



Picture 3-21 Row Status and Exclusion

Field	Values range	Description
1	Row status bar	The icon color indicates the row status: Green → row OK Yellow → row switched off by means of the tramline (row exclusion) button Red → row alarm/error Grey → row excluded (<i>not active</i>)
2	Value in cm	Tramline (row exclusion) button:  1 active row  3 row off.  4 excluded row (this button is not active)

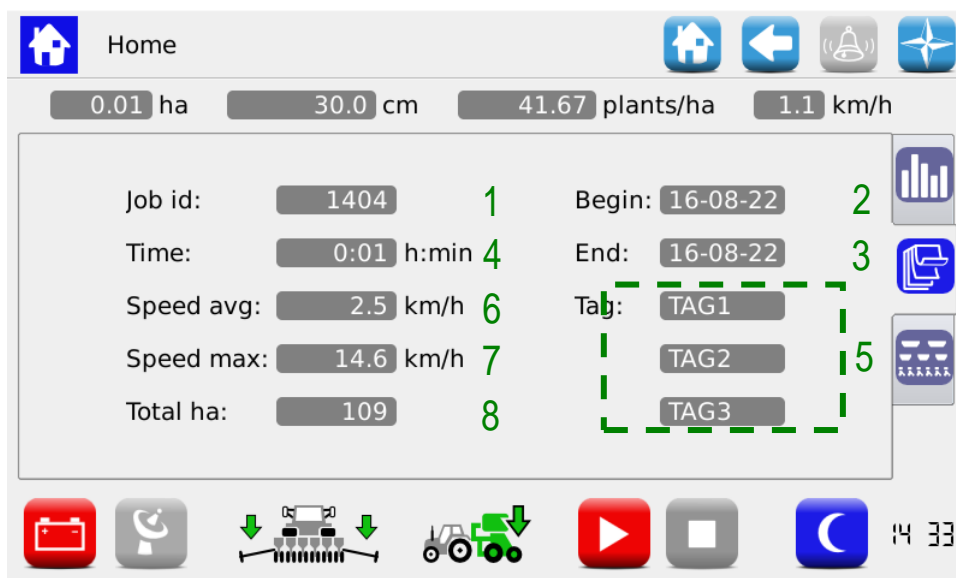

If a row is off, an alarm will sound continuously (3 consecutive bits) to remind the operator that the row has to be reactivated as soon as possible.

3.7.2. Summary information about the job 

Picture 3-22 Job summary information

Field	Description
1	Unique progressive number assigned to the job
2	Job starting date and time
3	Job ending date and time
4	Time worked
5	Tags related to the job's name
6	Average working speed in [km/h]
7	Maximum working speed in [km/h]
8	Total ha-counter of the machine

3.7.3. Synoptic

It allows to enable and disable the rows motors and to quickly access the setup functions, (see chapter 3.6). It also gives a graphical overview on the devices status.

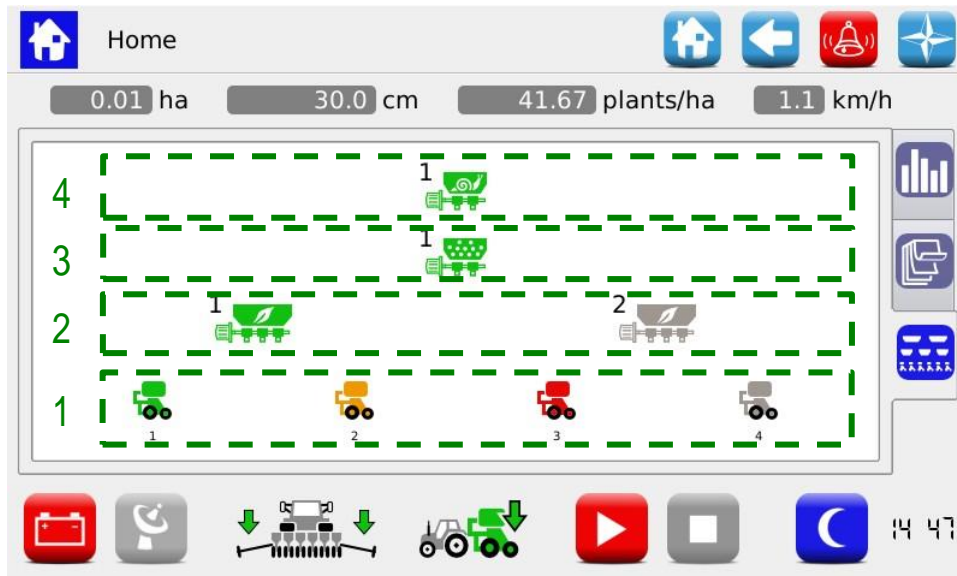

Picture 3-23 Synoptic

Field	Description
1	Distributors status icons The icon color indicates the row status Green → row OK Yellow → row deactivated by means of the row exclusion button Red → row alarm/error Grey → row excluded (not active)
2	Fertilizers status icons. The icon color indicates the device status. Green → distributor OK Red → distributor error Grey → distributor excluded (not active)
3	Status icons micro-granulator A The icon color indicates the device status.
4	Status icons micro-granulator B The icon color indicates the device status.

If pressed, the devices icons, allow to access the diagnostics, setting, activation/deactivation pop-up windows.

3.7.4. Distributors pop-up windows

These pop-up windows allow to view the status of the distributors related devices, to check if they are enabled and to quickly access the product distribution parameters setting menu

Path:

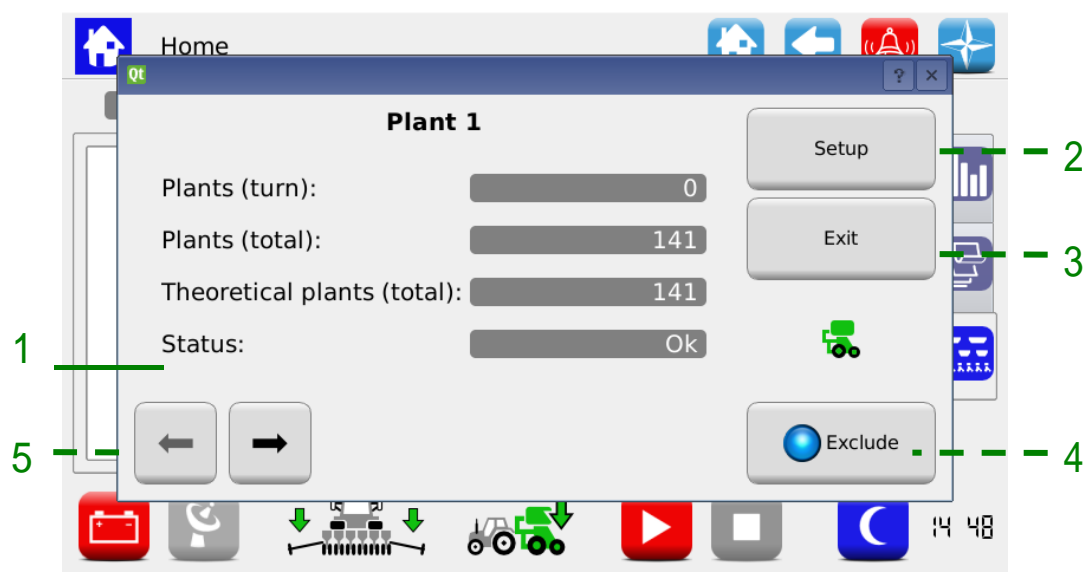

Picture 3-24 Distributor synoptic

Field	Description
1	Indication of the device status OK → no active alarms Disabled → device excluded (not active)
2	By pressing this button, the Setup menu window activates (see SETTINGS chapter), on the Tab corresponding to the distributors.
3	This button closes the window
4	This button enables/disables the device
5	Navigation buttons allowing to select the device you want to operate on

3.7.5. Disable distributor

The distributor enable/exclude function is used to permanently exclude it from transplanting. Contrary to the deactivation through the **row exclusion** button (see paragraph 3.7.1), the Enable/Exclude button also allows to exclude the row from the sown hectares calculation. Pressing this button you can modify the value in the Active Rows field, in the **Settings** window of the **Machine** Tab.

This function is only used in case of machines where it is possible to vary the elements number.

Warning!: the elements number is not changed in case some rows are excluded, so that the disabled elements will keep their address, even if they do not take part to the transplanting activity (see pictures below).

Example 1:

9 rows machine. All distributors enabled, row distance 45cm.

→ Active rows: 9

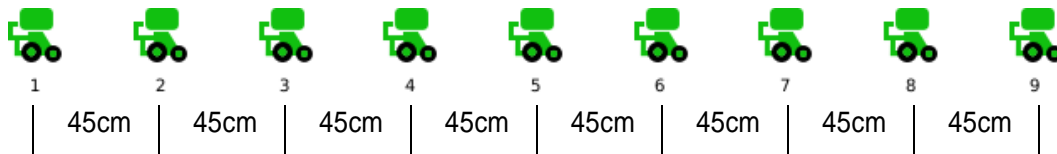

Example 2:

9 rows machine. Distributors 4 and 6 disabled, row distance 75cm.

→ Active rows: 7.

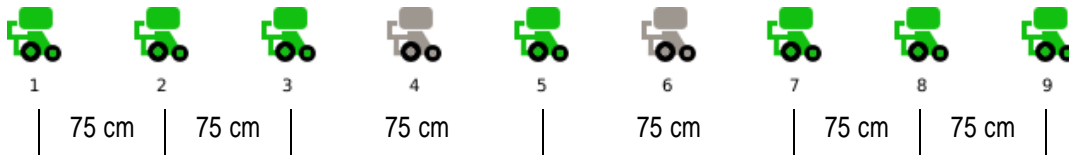

The elements 4 and 6 on the machine will be lifted, as to ensure a 75cm row distance between the elements 3 and 5 and the elements 5 and 7.





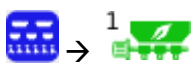

3.7.6. Fertilizer spreader, A and B micro-granulators pop-up windows

These pop-up windows allow to view the devices status, to check if they are enabled and to quickly access the product distribution parameters setting menu

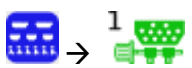
Path:

 → 1  for the fertilizer spreader

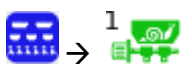
 → 1  for the A micro-granulator

 → 1  for the B micro-granulator

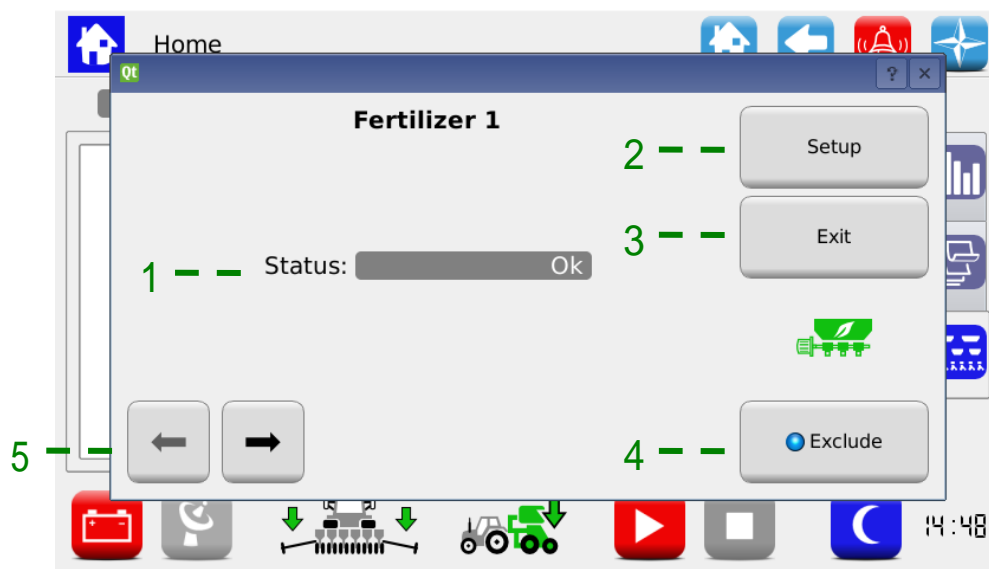











Picture 3-25 Fertilizer spreader synoptic

Field	Description
1	Indication of the device status OK → no active alarms Disabled → device excluded (not active) Alarm → device alarm
2	By pressing this button the Setup menu window activates (see chapter 3.6), on the Tab corresponding to the selected device. For ex.: if the pop-up window has been opened pressing on Fertilizer spreader 1, the Fertilizer spreader Tab opens. In case of changes, the settings will remain valid for all devices of the same type.
3	This button closes the window
4	Enable/Exclude device button
5	Navigation buttons allowing to select the device you want to operate on

3.7.7. Transplanting job

In order to proceed with the transplanting, you need to start a job.

If the transplanting job is inactive (job indicator off →  ), the motors do not react to any movement of the machine.

Button	Description
	<p>Click on this button to start a transplanting job.</p> <p>The job status indicators will turn green   ;</p> <p>When the job is active the “Prefill” step is immediately performed, if it has been enabled in the configuration.</p> <p>After that the system waits for the tractor’s movement on the field which determines the electric motors movement.</p> <p>The partial ha-counters and the plants counters are reset at the beginning of the transplanting activity.</p>
	<p>Press the button to resume a transplanting job which you had previously paused.</p> <p>In this case a “Prefill” is carried out only in case the PTO had been switched off during the pause.</p> <p>The partial ha-counter and the plants counter restart from the value indicated before the pause.</p>
	<p>Press the Pause button to temporarily interrupt the transplanting job without resetting the statistical counters related to the already started job.</p> <p>The job status indicators will turn yellow   ;</p>
 	<p>It finishes the transplanting job. The job status indicators will turn  .</p> <p>After a job is finished, a number of information about the job is saved in the internal storage. A status window indicates this activity. As soon as the status window closes, it will be possible to start a new job.</p>

3.8. ALARMS

The alarms and warnings are reported in a pop-up window like the one shown in the picture.

The  button allows to acknowledge the alarm and to close the window, but it does not cancel the alarm.

There are various kinds of alarms. According to the kind of alarm, it is possible to cancel it (the alarm status is eliminated) automatically or through a system rebooting, pressing the battery disconnect switch.

Category	Background colour	Buzzer	The pop-up window closes	Description
Unrecoverable emergency	Red	5 continuously repeated bips	Manual, pressing the alarm acknowledgment button	It is not possible to continue seeding. Power must be removed from the system
Recoverable emergency				It is not possible to continue seeding. The system must be disconnected from the power supply
Standard error		1 bip		It is possible to continue seeding but the device showing an error is not functioning properly
Warning	Yellow	1 bip	Automatic after 3 seconds	It is possible to go on seeding but the operator should be aware of the situation.

The already checked (acknowledgment button pressed) but still active errors, will be visualized in the window in a lighter background colour.

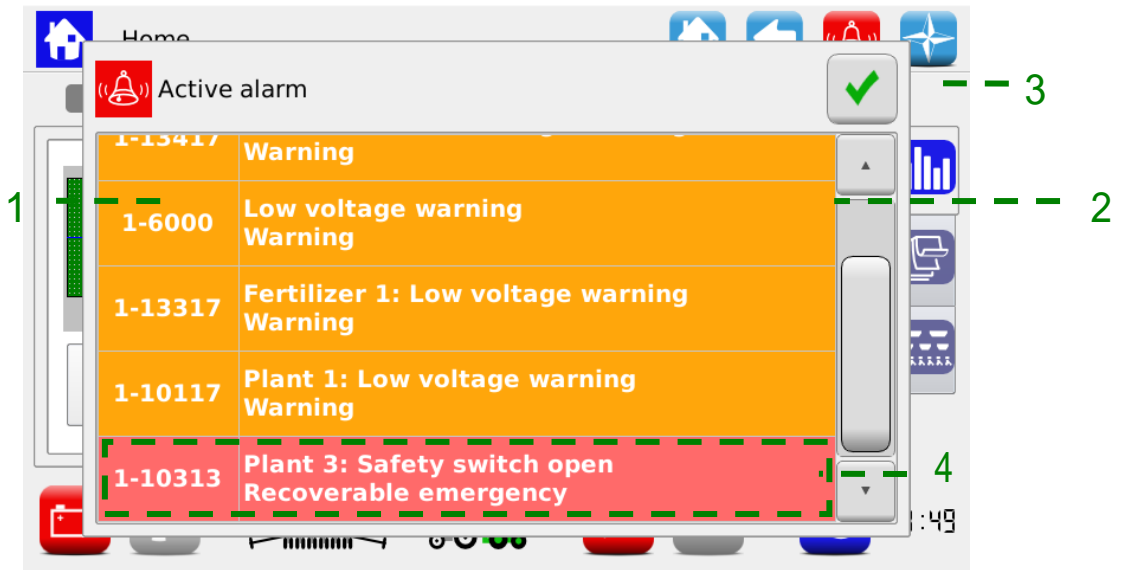

Picture 3-26 Active alarms

Field	Description
1	Alarm code
2	Alarm description Alarm category
3	Alarm acknowledgment button
4	Active alarm which has already been acknowledged (grey text)

Error code	Message	Solution
1060	Error overflow 1	Contact technical support
1061	Error overflow 2	Contact technical support
1062	Internal error	Contact technical support
1063	Log checksum failure	Contact technical support
1470	Connection timeout ECU / HMI	Check CAN cable connection between ECU and HMI
1471	Invalid protocol version debug	Not active on customer release
1472	Invalid protocol version	SW version of ECU and HMI are not compatible. Make sure that latest SW updates have been correctly downloaded to ECU and HMI. This error could occur during the software update if not all the devices have been updated with the new software. In that case it is recommended to update the software on all devices: the error will be automatically cleared
1480	Missing connection ECU / MD	Check CAN cable connection between ECU and DMD. Check supply cable to ECU. Check battery voltage
1481	Connection timeout ECU / MD	Check CAN cable connection between ECU and DMD
1490	Initialize timeout (%1)	Contact technical support
1550	Connection timeout ECU / remote terminal	Check connection between ECU and remote terminal
1600	Machine taxing position	Machine in taxing position (lifted) If this is happening when machine is supposed to be seeding, check cabling and machine position sensor
1610	Pressure sensor failure	Check connection of pressure sensor
1611	Pressure out of range	Adjust PTO speed so that vacuum pressure is within the range
1612	Pressure range min > max	Check min and max limit setting of pressure so that min < max
1701	MD protocol error	Update DMD with latest SW and check that addressing procedure has been correctly completed
1703	Configuration and setup parameters lost	Machine configuration parameters have been reset to default. Check and correct configuration parameters where applicable
1801	Invalid configuration or MD address	Check MD fuses. Addressing procedure of DMD has to be performed
2000	Data checksum	Contact technical support
2001	Invalid checksum	Contact technical support
2003	Debug mode	Non active on customer release
2007	Event log failure	Contact technical support
2008	FRAM checksum error	Contact technical support
2009	FSM queue overflow	Contact technical support
2100	Cpu watch dog	Contact technical support
2101	Software trap	Contact technical support

Error code	Message	Solution
2200	Speed sensor failure	Check speed sensor cabling
2500	Distributor parameters mismatch	Not possible to set that combination of parameters (number of disk holes, seeding distance): change the set parameters
2501	Group B parameters mismatch	Not possible to set that combination of parameters (number of disk holes, seeding distance): change the set parameters
2502	Group C parameters mismatch	Not possible to set that combination of parameters (number of disk holes, seeding distance): change the set parameters
2503	Group D parameters mismatch	Not possible to set that combination of parameters (number of disk holes, seeding distance): change the set parameters
2504	Spare parameters mismatch	Not possible to set that combination of parameters (number of disk holes, seeding distance): change the set parameters
2510	Distributor speed too high	Reduce tractor speed
2520	Planting job not active	Start the job by pressing the relative button
6000	Low voltage	Check speed sensor cabling. Check battery voltage
6001	Power failure stop	Check speed sensor cabling. Check battery voltage

xx = it indicates the motor which generated the error		
1-32	Seeding disc	1-32
33-40	Fertilizer spreader	1-8
49-56	Micro-granulator A	1-8
57-64	Micro-granulator B	1-8
Error code	Message	Solution
1xx00	Overcurrent	Cycle power of the system from battery disconnect.
1xx01	Motor high temperature	Let motor cool down. Check mechanical arrangement to check that there aren't unwanted frictions, damage bearings, etc.
1xx02	High voltage	Check PTO speed to be according to specifications. Check alternator voltage. Check battery connection and fuses
1xx03	Low voltage	Check PTO speed to be according to specifications. Check alternator voltage. Check battery connection and fuses
1xx04	PCB high temperature	Let motor cool down. Check mechanical arrangement to check that there aren't unwanted frictions, damage bearings, etc.
1xx06	High I2T	Non active on customer release
1xx07	Rotor lock	Check seeding disk for stuck seeds or distributor of stuck/blocking product
1xx08	Motor too high temperature	Let motor cool down. Check mechanical arrangement to check that there aren't unwanted frictions, damage bearings, etc.
1xx09	PCB high temperature	Let motor cool down. Check mechanical arrangement to check that there aren't unwanted frictions, damage bearings, etc.
1xx10	Overspeed error	Cycle power of the system from battery disconnect. Contact supplier if not solved
1xx11	Heart beat ECU missing	Check CAN cable connection between ECU and DMD. Check supply cable to ECU. Check battery voltage
1xx12	Find rotor position error	Non active on customer release
1xx13	Safety switch open	Close lid or seeding element cover. Check security switch
1xx14	Pwm control volt	Cycle power of the system from battery disconnect. Contact supplier if not solved
1xx15	Position control error	Cycle power of the system from battery disconnect. Contact supplier if not solved
1xx16	Blocked Seeding disk	Check seeding disk for stuck seeds or distributor of stuck/blocking product.
1xx17	Low voltage	Check PTO speed to be according to specifications. Check alternator voltage. Check battery connection and fuses

xx = it indicates the motor which generated the error		
1-32	Seeding disc	1-32
33-40	Fertilizer spreader	1-8
49-56	Micro-granulator A	1-8
57-64	Micro-granulator B	1-8
Error code	Message	Solution
1xx26	Seed selector	Verify that there isn't any material (seeds, dust, etc.) preventing the correct movement of seed selector. Verify that seed selector cam is fitted properly on seed selector motor shaft. From the menu\Diagnostic\Test\Seed Selector, press "Homing" button to perform the homing procedure
1xx30	Generic	Recoverable emergency
1xx80	High number of doublets	Check at every single turn, adjust the seed selector position to a lower set value.
1xx81	High number of missings	Check at every single turn, adjust the seed selector position to an higher set value.
1xx83	High number of missings	Quick check less than one turn, check the pressure rate and the seeds selector position
1xx84	Prefill not completed	Verify that vacuum is correct and seeds are present in the hopper
1xx85	High number of doublets	Long period alarm, adjust the seed selector position to a lower set value.
1xx86	High number of missings	Long period alarm, adjust the seeds selector position to a higher set value, for example to detect a plugged disk hole.
1-1xx14	Pwm control volt	Cycle power of the system from battery disconnect. Contact supplier if not solved.
1-1xx15	Position control error	Cycle power of the system from battery disconnect. Contact supplier if not solved.
1-1xx16	Blocked Seeding disk	Check seeding disk for stuck seeds or distributor of stuck/blocking product
1-1xx17	Low voltage	Check PTO speed to be according to specifications. Check alternator voltage Check battery connection and fuses
1-1xx26	Seed selector	Verify that there isn't any material (seeds, dust, etc.) preventing the correct movement of seed selector. Verify that seed selector cam is fitted properly on seed selector motor shaft. From the menu\Diagnostic\Test\Seed

xx = it indicates the motor which generated the error		
1-32	Seeding disc	1-32
33-40	Fertilizer spreader	1-8
49-56	Micro-granulator A	1-8
57-64	Micro-granulator B	1-8
Error code	Message	Solution
		Selector, press "Homing" button to perform the homing procedure
1-1xx80	High number of doublets	Adjust the seed selector position to a lower set value.
1-1xx81	High number of missings	Adjust the seed selector position to a higher set value.
1-1xx82	Deviation from theoretical investment	Check seeding disc and seeds selector position.
1-1xx83	High number of missings ⁴	Verify selector position, pressure rate or the presence of the seeds in the hopper.
1-1xx84	Prefill not completed	Verify that vacuum is correct and seeds are present in the hopper.

3.9. USB MENU, SOFTWARE UPDATE AND PROTOCOL CHANGE

It is possible to update each system device via the HMI.

To perform an update you need an USB stick containing the software versions you want to update.

Where applicable, you can perform the update in the following order:

- 1) HMI
- 2) ECU
- 3) DMD

The “Protocols” function allows to switch from the ROJ machine (therefore from the ECU system with standard HMI Agrimate), to the ISOBUS ARAG systems, controlled by a proprietary control unit called “iBX100 Planter”.

In the following screen you can choose whether to update the software of the different devices or to change the MDs communication protocol.

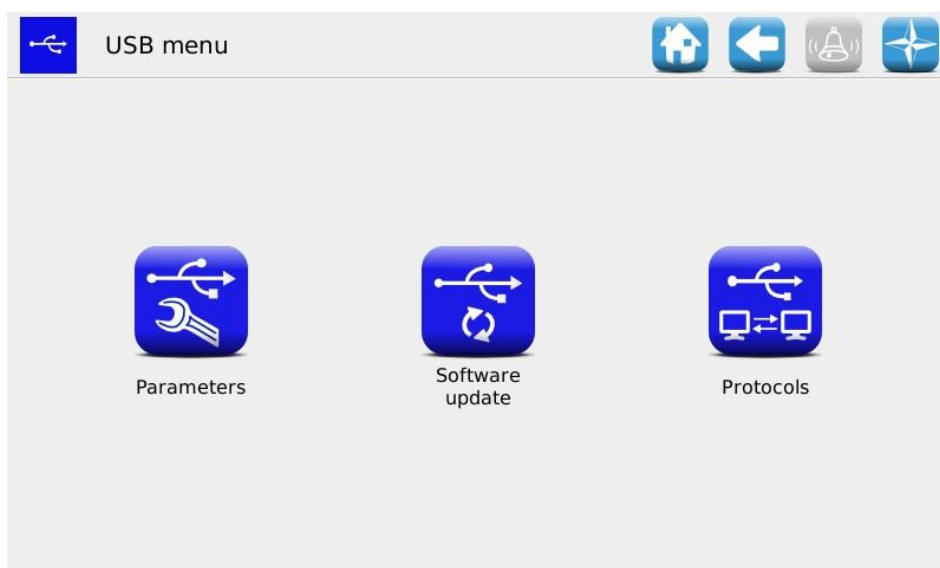

Picture 3-27 USB Menu

The accessible submenus on the operator's or OEM assistance level are “Software update” and “Protocol”.

3.9.1. Software update

Path:



The following screen allows the user to decide which part of the system should be updated.

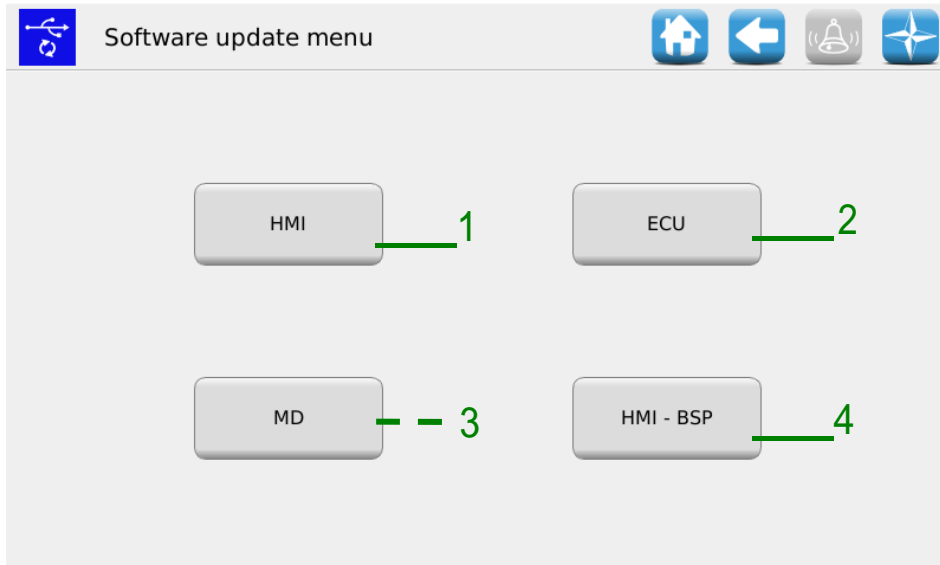

Picture 3-28 Software update

Field	Description
1	It allows to update the HMI software
2	It allows to update the ECU board software
3	It allows to update the motors software
4	It allows to update the PSB for the HMI (only ROJ service)

3.9.2. HMI software update

Path:



Picture 3-29 HMI update

Selecting the desired SW from the list and pressing the button **1** it is possible to update the HMI software. After the update the console shuts off automatically and the system reboots.

3.9.3. ECU software update

Path:

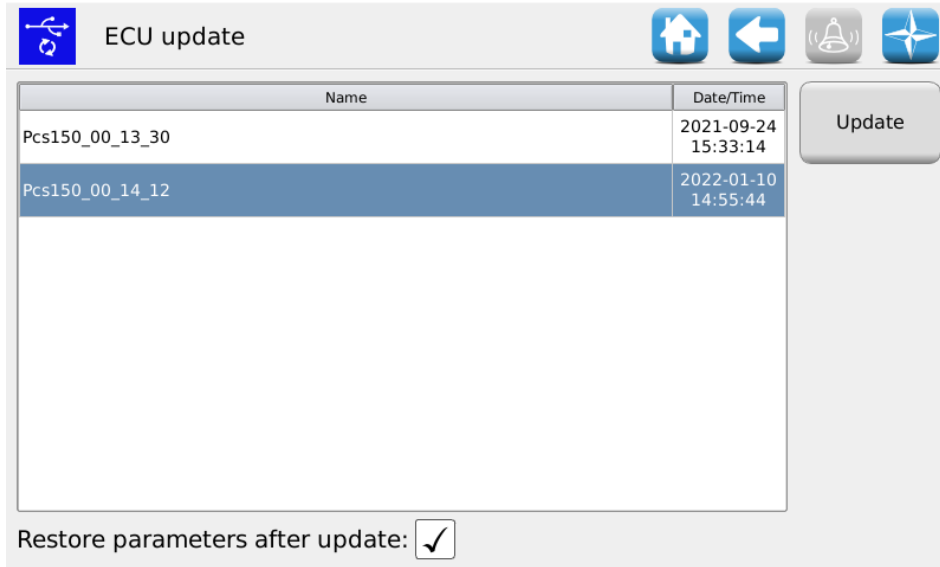

Picture 3-30 ECU update

Selecting the desired software from the list and pressing the button **1**, it is possible to update the ECU software.

Remarks:

1. After the ECU software update it is possible that an “*Invalid protocol version*” error is displayed. In that case, just go on with the updating procedure: the error is deleted after the HMI has been updated too.
2. Once the ECU software update is finished, it is possible that one or more errors are displayed according to the previously installed software version, as follows:

Configuration and setup parameters lost
Invalid configuration or MD address
Data checksum
Invalid checksum

In that case, follow the procedure described in the paragraph below in order to confirm the addressing and to restore the parameters.

3.9.4. How to confirm the addressing and restore parameters

1. Close the alarms window via the green check mark. The "MD Addressing" window opens.
2. Wait 10 seconds before pressing the "Addressing" button.
3. An automatic procedure is performed after the message: "All devices correctly addressed" is displayed with a green check mark. Press the "Exit" button.
4. The "Critical Parameters Setup" window is displayed. Press the "Confirm parameters" button.
5. Access the window Menu\Terminal and press the "Access" button.
6. Select "OEM Service" from the list. Enter the password for the OEM service access and confirm by double clicking on the green check mark.
7. Access the window Menu\USB\Parameters\.
8. Select the (PAR_<date_time>) file. If there are many files, select the most recent one.
9. Press "Upload all/Config/Setup". If the uploading has been successful, the "Parameters loaded" message will be displayed indicating that the parameters have been correctly restored.

3.9.6. MD software update

Path:

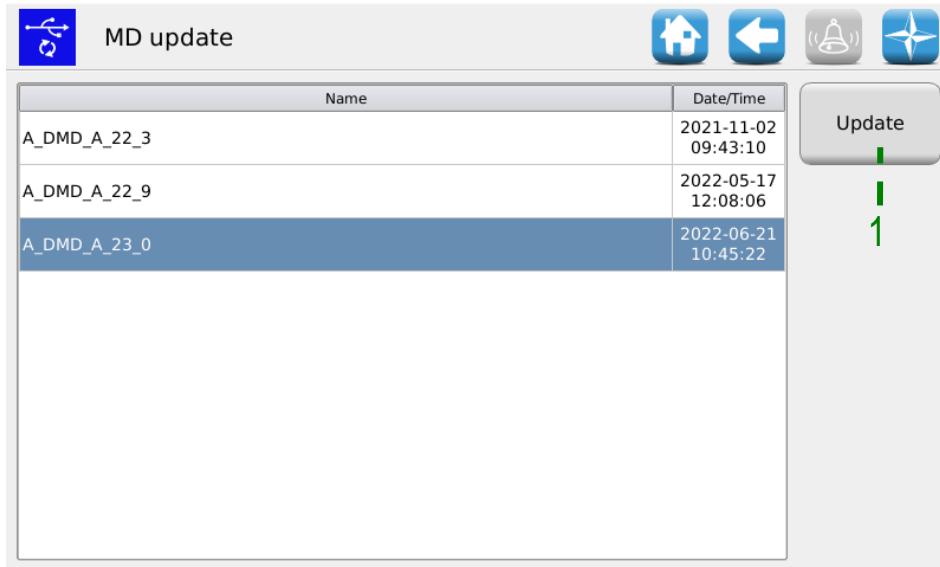

Picture 3-31 Motors update

Selecting the desired software from the list, and pressing the 1 button, the following pop-up window is displayed where it is possible to choose the motor (and therefore the elements: transplanting unit, fertilizers or micro-granulators) to be updated.

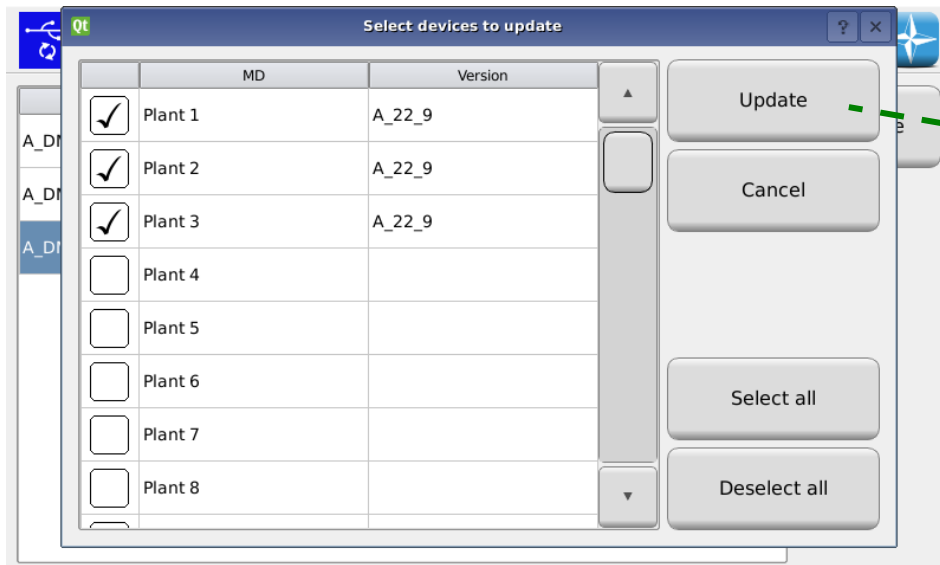

Picture 3-32 Selection of the motors to update

Pressing the 1 button after the selection, the selected MDs update starts.



Before updating the motors, it is recommended to address them to avoid the risk of an address conflict.

3.9.7. MD protocol change

Path:

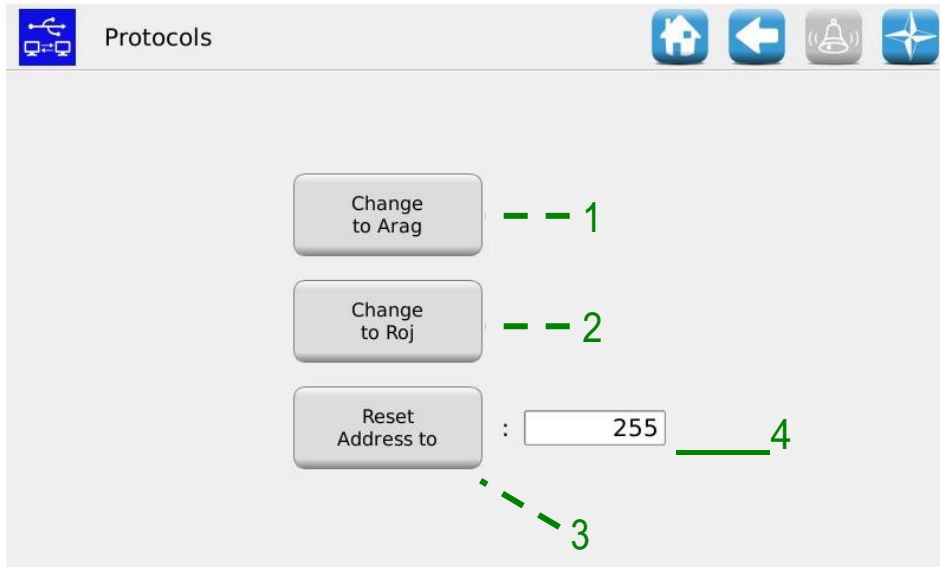

Picture 3-33 Protocols

Field	Description
1	It allows to switch from the ROJ machine to the ARAG machine. Through this action all MDs will be assigned an address 7F.
2	It allows to switch from the ARAG machine to the ROJ machine. Through this action all MDs will be assigned an address 20.
3	It allows to reset all MDs addresses. The reset address can be selected from the 4 check box.
4	It allows to select the reset address

3.10. STATISTICS

This menu allows to display and save on your USB stick some statistics related to the active transplanting job and the system event log.

Path:

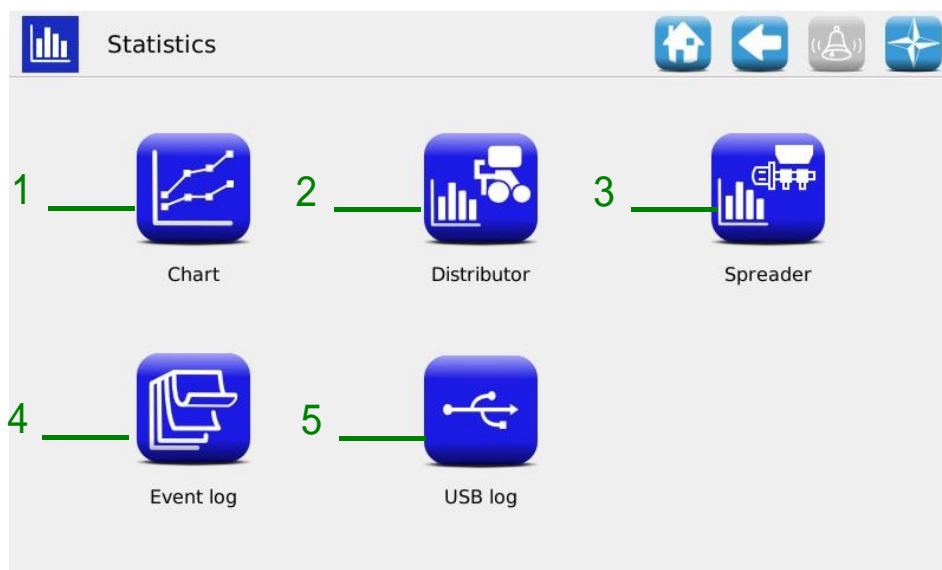

Picture 3-34 Statistics

Field	Description
1	Chart function (only accessible by ROJ Service)
2	Statistics relative to the distributors elements
3	Distributors statistics (fertilizer spreader and micro-granulators)
4	System events log
5	Events and statistics storage

3.10.1. Statistics

This window contains statistic information about the transplanting elements, both the individual (“Distributor 1” columns...) and the total (“All” column) ones.

Path:



Distributor statistics					
	Distributor 1	Distributor 2	Distributor 3	Distributor 4	All
Plants (turn)	10	10	10	10	
Average distance (turn) [cm]	30.0	30.0	30.0	30.0	30.0
Plants (total)	51	51	51	51	
Theoretical plants (total)	51	51	51	51	
Average distance (total) [cm]	30.0	30.0	30.0	30.0	
Average population (total) [plant/ha]	41666.0	41666.0	41666.0	41666.0	41666.
Partial [ha]					-
Total [ha]					108.5

Picture 3-35 Elements Statistics

Field	Description
Plants (turn)	Number of plants detected by the seed sensor at the previous turn, if the plants sensor is active, otherwise number of cups of the distributor
Average distance (turn) [cm]	Average seeding distance referred to the previous turn
Plants (total)	Number of total plants detected by the seed sensor during active transplanting job, if the plants sensor is active, otherwise number of theoretical plants
Theoretical plants (total)	Total number of plants which should have theoretically been planted during the active transplanting job.
Average distance (total) [cm]	Average transplanting distance referred to the active transplanting job
Average population (total) [plants/ha]	Average population referred to the active transplanting job.
Partial [ha]	Partial ha-counter (it is reset at the beginning of each new transplanting job)
Total [ha]	Partial ha-counter for the machine

3.10.2. Distributors statistics

This window contains statistic information about the distributors (fertilizer spreaders and microgranulators), both individual and total (“All...” column).

Path:



Spreader statistics						
	Fertilizer 1	Fertilizer 2	All fertilizer	Micro A 1	All micro A	Micro B 1
Quantity [kg]	0.5	0.2	0.6	-	-	-
Partial [ha]						
Total [ha]						

Picture 3-36 Distributor statistics

Field	Description
Quantity [kg]	Quantity of product spread during the active transplanting job
Partial [ha]	Partial ha-counter (it is reset at the beginning of each new transplanting job)
Total [ha]	Partial ha-counter for the machine

3.10.3. Event log

Here you can see the system event log (alarms, parameters change, start and stop of the transplanting job, etc.).

Path:



Picture 3-37 Event log

Field	Description
1	Event time and date
2	Unique identifier for the transplanting job
3	Event name and icon
4	Detailed event description
5	Press this button to save the Event Log (you will need a USB stick)

3.10.4. Event and statistics storage

In order to give some information to the Technical Support and ask for assistance, it is possible to download different kinds of logs from the system, using the functions accessible from Menu\Statistics\Save on USB log. To access those functions, insert a USB stick in the relative HMI slot.

Path:

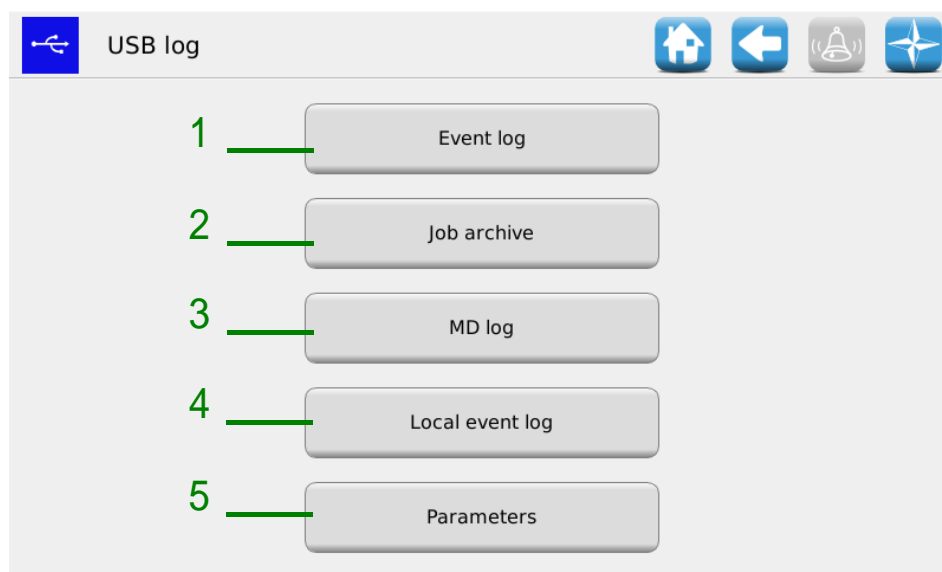

Picture 3-38 Save to USB

Field	Description
1	If you press the "Event log" button, an event log containing all the errors, the parameters changes, etc. will be saved.
2	Pressing the "Job log" button you can save a file containing detailed information about the seeding jobs.
3	The "MD log" button opens a selection window where it is possible to select the MDs for which you need to download some information. This operation can take about 30 seconds for each MD.
4	Press the "Local event log" button to display some debug information
5	The "Parameters" button allows you to save the current system configuration parameters.

The above procedure will create on the USB stick a directory called **gt4_<nnnn>** (where <nnnn> is the ID number of the HMI in use) containing some files. It is possible to send this directory to the Technical Support via email.

3.11. TERMINAL

In this window it is possible to configure some settings related to the HMI terminal.

Path:



General Tab

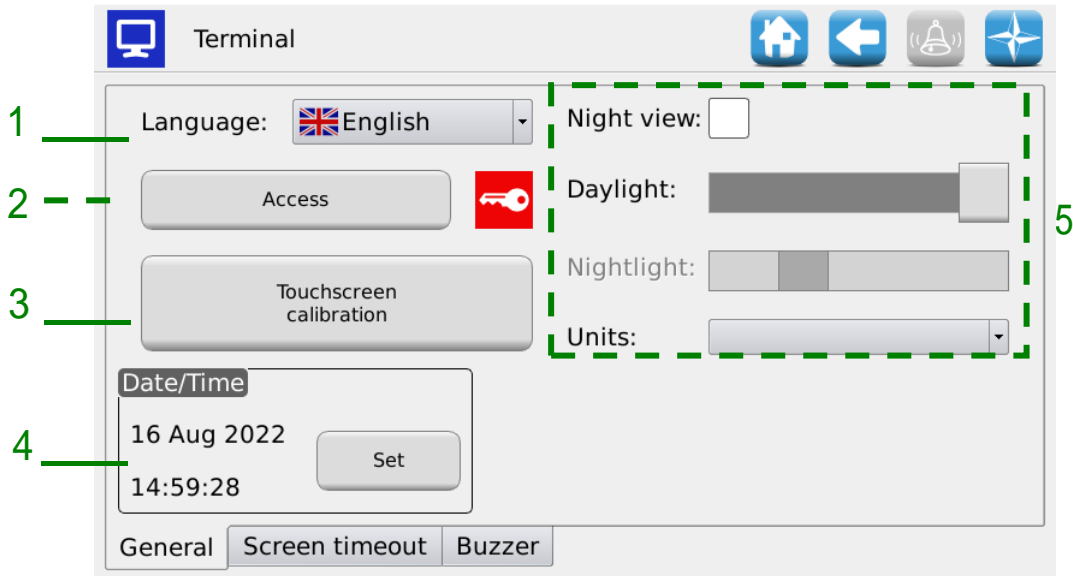

Picture 3-39 Terminal, General tab

Field	Description
1	Select the HMI terminal language
2	Select the access level (see also the chapter ACCESS LEVELS)
3	Touchscreen calibration function
4	Date and Time setting for the HMI terminal
5	To set up the day/night backlight levels. The slider controls allow to independently adjust the light level in case of day/night setup. To select the night light slider control, tick the “Night view” check mark.

Screen Timeout Tab

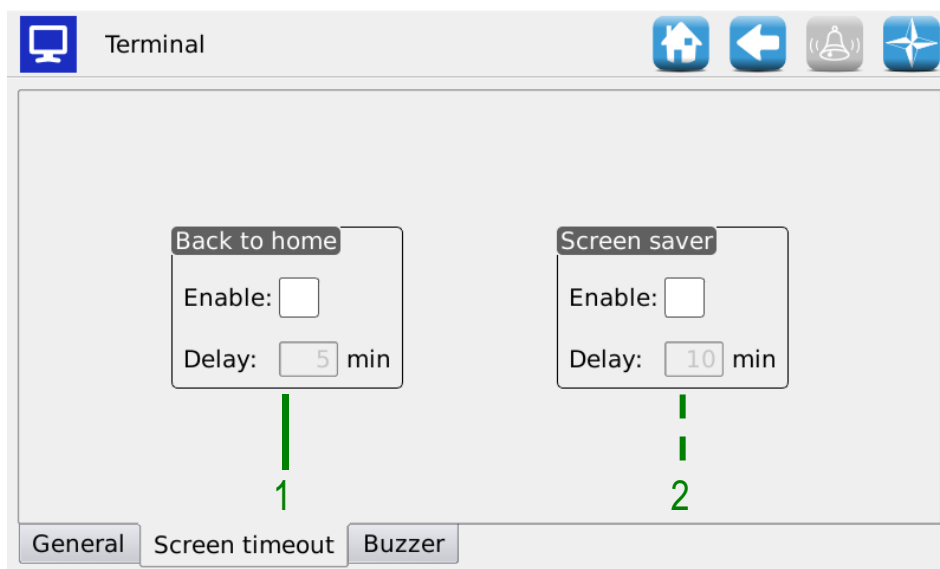

Picture 3-40 Terminal, Screen Timeout tab

Field	Description
1	Here it is possible to enable and set up the Home page return function delay: If enabled, in case of inactivity, once the set time has expired, the terminal will come back to the Home screen.
2	Here it is possible to enable and set up the Screensaver function delay: If enabled, in case of inactivity, the screen backlight is reduced to a minimum.

Buzzer Tab

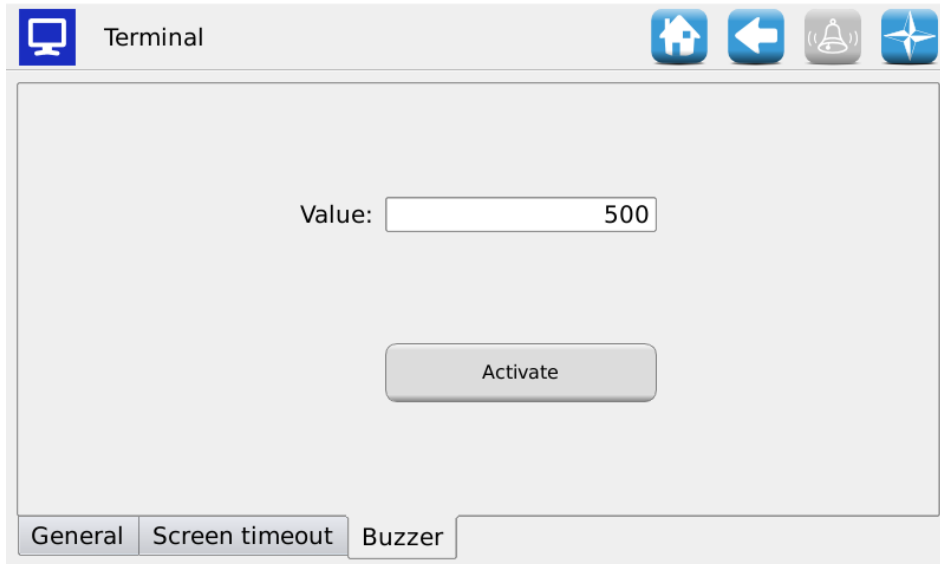

Picture 3-41 Terminal, Buzzer tab

In this page it is possible to regulate the sound intensity of the console built-in buzzer. The values range from 50 to 1000.

A check mark on "Legacy Buzzer" allows you to make the updated software compatible with the old console hardware versions.

3.12. TEST

Path:



Simulation tab

This tab allows to simulate the tractor speed. Use this window to simulate a seeding job session without having to effectively turn the ground wheel of the machine.

This test mode is accessible in all the seeding job conditions. The MDs will only work if they have been activated (they should neither be excluded nor stopped for the row exclusion function) and when the seeding job is active. During this test all functions like the seeds count, the hectares count and so on will be active just like the machine was working on a real field.

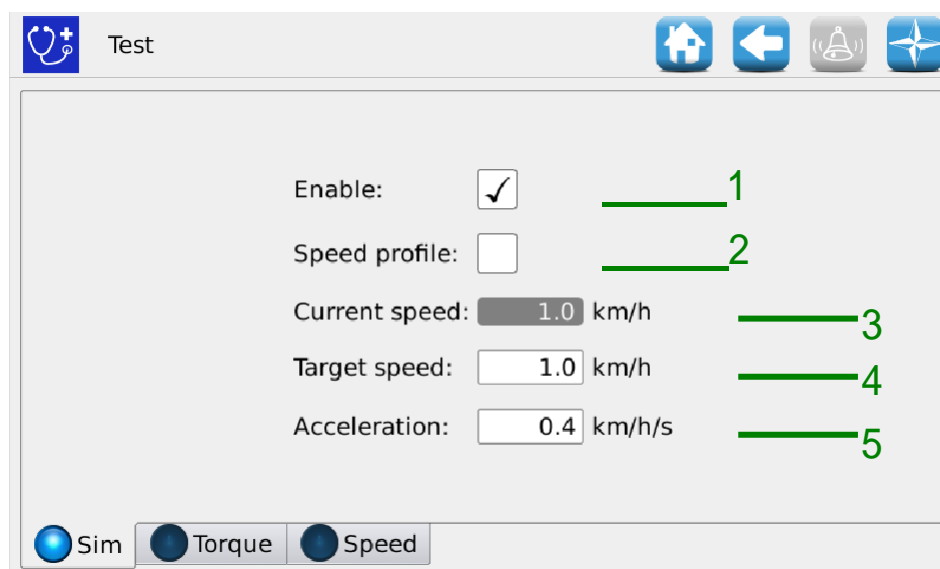

Picture 3-42 Test, Simulation tab

Field	Description
1	If this option is selected it enables the simulation. The speed increases until the <i>Target Speed</i> value is reached, following the acceleration ramp as specified in the <i>Acceleration</i> field. When it is unselected, the speed starts to decrease until the 0 value is reached, following the deceleration ramp specified in the <i>Acceleration</i> field.
2	If this option is selected, it enables the simulation of a "real" tractor speed profile (data detected on the field). In this case the Speed and Target acceleration fields will be used.
3	Current speed: Value of the simulated speed of the system in that moment

Field	Description
4	It indicates the simulation of the top speed to be reached. The value is expressed in km/h. The corresponding km/h value should be calculated as follows: Speed [km/h] = 3.6*Speed[mm/s]/1000
5	It indicates the tractor speed to be simulated. The field value is expressed in km/h/s

Torque tab

In this tab it is possible to Read the MD torque and speed (sampling every 200ms), for the distributors and the seeding discs.

This test mode is accessible in all working conditions.

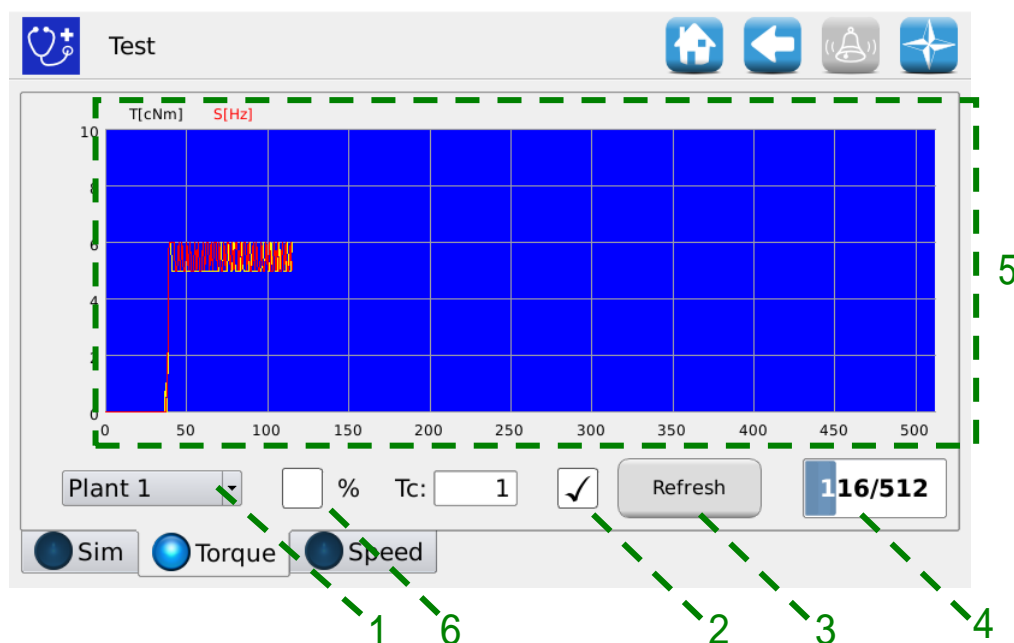

Picture 3-43 Test, Torque tab

Field	Description
1	Selection of the MD to be monitored
2	Select this case to activate the torque monitoring function. The torque value is sampled each 200 ms. The window is refreshed every 1sec with new samples.
3	Update button: if pressed the samples values are refreshed. Insert a USB stick in the console slot, deselect the "Enable" check box and press "Refresh" to store all the data on the USB drive. The file name will be TORQ_<data>_<time>.txt
4	Number of valid samples for the window in the chart.
5	Torque and speed chart window. The torque value is expressed in cNm and the speed in Hz.
6	A check mark on % allows to see the Torque and Speed values expressed in percentage with reference to the maximum torque and speed.

Speed Tab

In this tab it is possible to test each motor, a group of motors or all the motors, controlling them in "speed mode", corresponding to the set tractor speed.

When using the "Speed" tab, all functions, i.e. seeds count, hectares count, and so on are disabled. You can use this window to carry out the motors running-in.

This test mode is only available when the seeding job is inactive or paused.

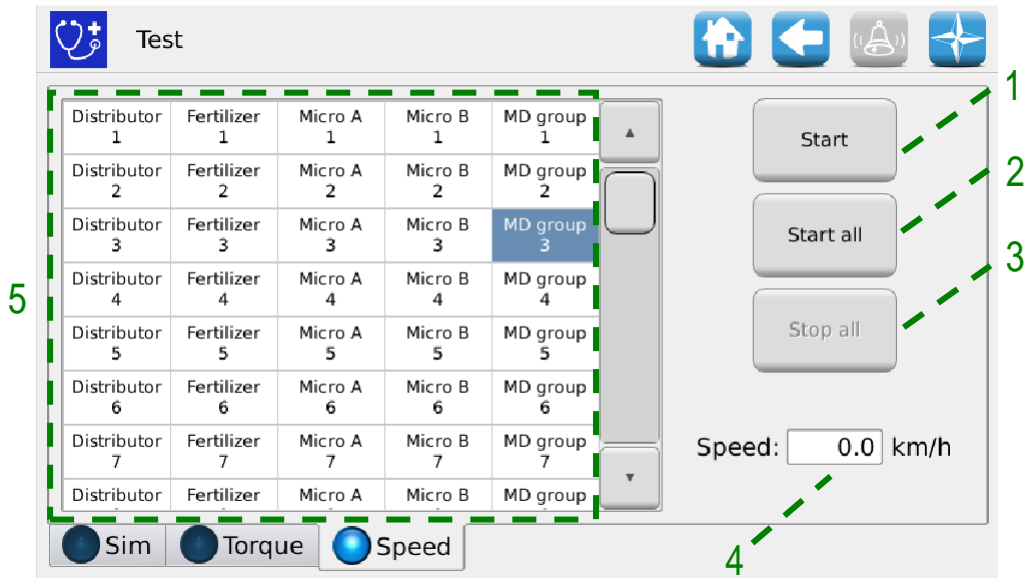

Picture 3-44 Test, Speed tab

Field	Description
1	The selected MDs start
2	All MDs start
3	All MDs are stopped
4	Tractor speed expressed in km/h
5	Motors selection window.

MAINTENANCE AND TROUBLESHOOTING

4.1. GENERAL INFORMATION ABOUT MAINTENANCE

Due to the inherent sturdiness of the PCS 150 system components, no particular preventive maintenance operations are required.

However in order to ensure the maximum equipment reliability and to avoid hazardous conditions, it is advisable to strictly follow the instructions and warnings given below.



*For safety reasons, all maintenance works on the power train must be carried out **ONLY** when the machine is stopped and disconnected from the power supply, by qualified trained and experienced personnel, having a suitable experience and knowledge of the PCS 150 system and of the equipment itself.*



Properly clean the operating area before starting maintenance.



Do not use any solvent!



After any maintenance task all materials having an impact on the environment (such as, for example, lubricants, dirty clothes, filter elements, etc.) must be disposed of properly in accordance with the applicable regulations.



*Ensure that the access of unauthorized personnel to the working area IS **FORBIDDEN** during maintenance tasks.*

At the end of any task, make sure that no used tools are left inside the equipment or into the electrical panel.

4.2. ORDINARY PREVENTIVE MAINTENANCE TASKS TO BE CARRIED OUT BY THE OPERATOR

Task	Frequency	Notes
Cleaning	Before long periods of inactivity	If cleaning with a high-pressure washer, do not direct the jet towards connectors and seals.
Tightness check	Every year, after long periods of inactivity (ex. at the beginning of the working season)	
Geared motors oil change	Not required	

4.3. MAINTENANCE / REPAIR TASKS ONLY ALLOWED TO SPECIALIZED PERSONNEL

Task	Frequency	Notes
Safety devices operation check	At the beginning of each season. During the season depending on the frequency of use	This control can be carried out by starting the motors through the test functions described in paragraph 3.12 and checking that, when each MD safety switch opens, the motor is stopped.

4.4. SPARE PARTS

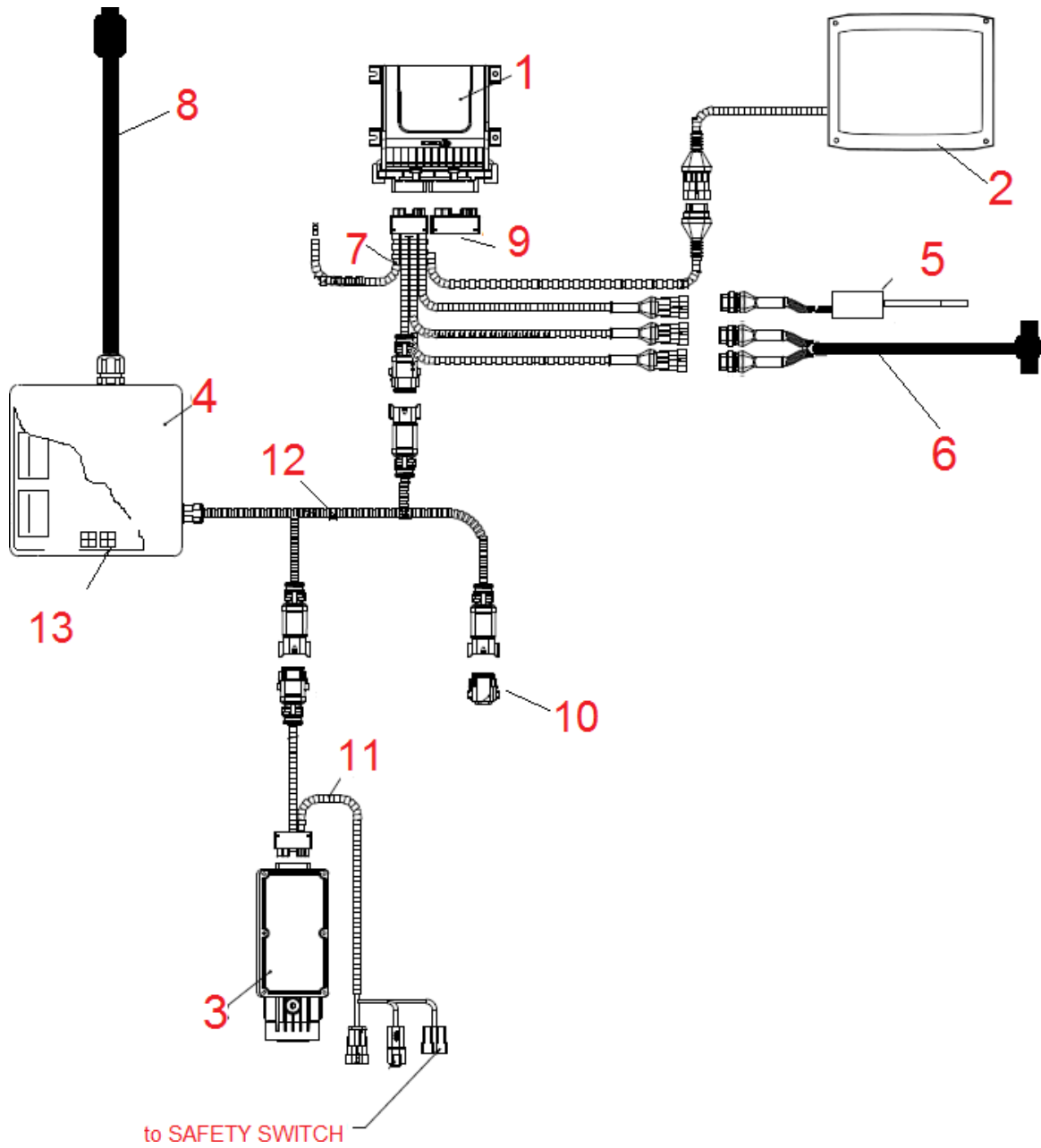

Code	Description	Ref. on wiring diagram
54T01068	PCS 150 ECU	1
58G00074	AGRIMATE GRAPHICAL CONSOLE	2
1406.601	DMD 0	3
56C00651	DEMETER SDB 3 + 3	4
05R01422	MECHANICAL SWITCH SENSOR	5
50A00176	MAGNET M9105/F26 FOR 05R01424	6
05R01424	MAGNETIC ENCODER HCW4	
05R01379	ECU 18P CABLE DEMETER	7
05R01411	SDB - ISO12369 CABLE	8
05R01334	ECU PLUG 30C	9
05R01381	CAN TERMINATION (DEUTSCH) DEMETER	10
05R01404	DMD DISTRIBUTION CABLE 3 POS	12
05R01385	CAN TERMINATION (MOLEX) SDB	13

Code	Description	Ref. on wiring diagram
DMD0 - without seed sensor⁵		11
05R01377	DMD CABLE - DISTRIBUTOR (TE) L = 1000	
05R01384	DMD CABLE - DISTRIBUTOR (TE) L = 1300	
DMD0 - With connector for MC Elettronica sensor⁶		11
05R01374	DMD CABLE - SEEDER (TE) L = 1300	
05R01375	DMD CABLE - SEEDER (TE) L = 1700	
05R01376	DMD CABLE - SEEDER (TE) L = 2300	
05R01387	DMD CABLE - SEEDER (TE) L = 3500	
DMD2 - Without sensor input		11
05R01474	DMD 2 CABLE - HOPPER L=1300	
05R01475	DMD 2 CABLE - SEEDER L=1700	
05R01494	DMD 2 CABLE - SEEDER L=2500	

⁵ Suitable to MDs for fertilizers and microgranulators

⁶ Tyco Superseal 3-poles connector

4.5. PROCEDURE FOR THE MD REPLACEMENT OR EXCHANGE

In case of MD motor failure, it is possible to proceed with the transplanting activity, in one of the following ways:

- Replacing the MD with a new MD
- Exchanging the faulty motor with another properly functioning motor already installed on the machine
- Removing the MD from the machine configuration

4.5.1. Replacing the MD with a new MD

1. Disconnect the system from the power supply via the battery disconnect switch
2. Disconnect the faulty MD cable from the MD side, using a 1/4" wrench.
3. Remove the screws which fix the motor to the support and remove the faulty motor from the distributor shaft.
4. Fix the new motor mechanically and connect the MD cable.
5. Power up the system via the battery disconnect switch
6. After the system has been started, an alarm 1-1801 "Invalid configuration or MD address" is displayed and an MD Addressing window is opened.
7. Press the "Addressing" button: the icon corresponding to the replaced MD starts flashing, indicating that the motor must be addressed.
8. Close the safety switch of the new MD to address the device.
9. Once the addressing has been completed, press the "Exit" button.

4.5.2. Exchanging the faulty motor with another functioning motor already installed on the machine

If no spare MD is available, you can decide to exchange the faulty MD with another motor mounted on the machine, in order to continue working (you can for ex. exchange a faulty motor related to the distributor with the motor related to the micro-granulator, in case this last function is not needed).

Warning!: The following procedure requires that the faulty motor is still able to communicate via the CAN line. In case an alarm 1-1801 "Invalid configuration or MD address" is displayed when starting the machine, even if the configuration has been changed, you need to follow the **Removing the MD from the machine configuration** procedure.

1. Disconnect the system from the power supply via the battery disconnect switch
2. Disconnect the faulty MD cables from the MD to be exchanged, using a 1/4" wrench.
3. Remove the screws which fix the two motors and extract them from the distributor shaft.
4. Exchange their position, fix the motor in the new position and reconnect the cables.
5. Power up the system via the battery disconnect switch
6. Make sure that no transplanting job is active (in that case press STOP).
7. Press the "MD addressing" button in the "Configuration" window to confirm.
8. Press the "Addressing" button: all devices have been addressed.
9. Press the faulty device icon and select "Unaddress MD"
10. Press the icon of the exchanged motor and select that motor from the "Unaddress MD" window.
11. The icon corresponding to one of the exchanged MDs starts flashing indicating that it has to be addressed.
12. Close the MD safety switch on the correct position to address the device.
13. The icon corresponding to the other MD starts flashing indicating that it has to be addressed.
14. Close the MD safety switch on the correct position to address the device.
15. Once the addressing has been completed, press the "Exit" button.

4.5.3. Removing the MD from the machine configuration

In case a spare MD is not available and if the faulty MD is not able to communicate on the CAN line, it is possible to remove the device from the machine configuration in order to proceed with the job.

This obviously requires a configuration modification as well as a change of the devices logical address.

If this problem arises the alarm 1- 1801 "Invalid configuration or MD address" is displayed when turning up the system, without changing any settings or MD connections.

1. Check the integrity of the fuse for the MD which is not able to communicate. If the fuse is blown, replace it.
2. Check the integrity of the CAN connection towards and from the faulty MD.
3. If the problem persists, disconnect the system from the power supply via the battery disconnect switch
4. Remove the fuse for the faulty MD but do not unplug the cable from the MD as it is used to keep the CAN connection towards the other motors.
5. Power up the system via the battery disconnect switch
6. After the system has been started, an alarm 1-1801 "Invalid configuration or MD address" is displayed and an MD Addressing window is opened.
7. Press the "Change configuration" button and modify the machine configuration in order to show the number of devices after removing the faulty one, and confirm the setting.
8. Press the "Addressing" button
9. Press a device icon to open the "Unaddress MD" window and select "All MDs"
10. Go on addressing all the machine with the new configuration.
11. Once the addressing has been completed, press the "Exit" button.

ROJ

Via Vercellone 11
13900 Biella (BI)
Tel. +39 015 84 80 111
Fax +39 015 84 80 209
E-mail: comm@roj.com
www.roj.it

Certified under ISO 9001 by DNV since
1996