

# SUPER ELF S3

## Instruction Manual



# ROJ<sup>®</sup>

**ROJ srl**

Via Vercellone 11  
13900 BIELLA - ITALY

Tel: (+39) 015 84 80 111

Fax: (+39) 015 40 58 15

comm@roj.com www.roj.com

**WARNING!**

- *Condensation could form on the Weft Feeder when it is moved from the cold environment of the warehouse to the warmer environment of the weaving room. Make sure that it is completely dry before connecting to power.*
- *Provide proper information to the people operating the weft Feeders.*
- *The installation, connection, adjustment, and maintenance of the Weft Feeder has to be performed by technically qualified personnel.*
- *The Loom's main power switch MUST be switched OFF before any replacing or connecting operation.*
- *Caution must be taken on the close vicinity of the Feeder. In normal working condition, it can start running without prior warning and the moving parts might cause injuries.*
- *Repairing any electrical part of the unit has to be carried out by Roj s.r.l. authorized personnel.*
- *Always use proper spare parts and accessories supplied by Roj s.r.l.*
- *Roj s.r.l. disclaims all responsibility for the improper use of the Feeder different from what described in the chapter 1. General Information.*

<b>INDEX</b>	<b>page</b>
<b>1. GENERAL INFORMATION</b>	
Super Elf S3 description	4
Super Elf S3 Technical Data	4
Pulsar HP brake description	4
Technical data of Pulsar HP	4
Other information about Super Elf S3	4
Features and Characteristics	5
<b>2. SETTING AND CONTROL ELEMENTS</b>	
Front control elements	6
Back panel control elements	7
<b>3. INSTALLATION AND CONNECTION</b>	
Electric connections	8
Diagram connection of the Voltage Supply Box	9
<b>4. SETTINGS AND OPERATION</b>	
How to set working parameters	10
Insertion length	11
Reserve sensor	11
Filling tensioner (Pulsar HP)	12
Sensors sensitivity settings	14
Maintenance	16
Photocells automatic calibration	16
Photocells information	16
Weft length adjustment	17
Winding direction and coils pitch adjustment	18
Reserve loading (Full air threading, only with funnel)	19
Reserve loading (Half air threading)	19
<b>5. TROUBLESHOOTING</b>	20
<b>6. ACCESSORIES</b>	
Funnel	21
Eyelet holder	21
Pulsar HP	21
Voltage Supply Box	22
<b>7. DECLARATION OF CE CONFORMITY</b>	25

## 1. GENERAL INFORMATION

### Super Elf S3 description

**SUPER ELF S3** is a Weft Feeder with **yarn separation** and direct **CAN-bus** communication with the Loom Control. The new Permanent Magnet motor and the Reserve sensor allow very fast reaction and accurate yarn storage control on the spool body. The new **Reflective type optical sensors** guarantee robustness and best performances in dust environments and with very fine yarns.

### Super Elf S3 - Technical Data

Power supply by means of the specific Roj Control Box:	<b>100 V dc – 24 V dc</b>
Weft feeding speed (pattern in advance info):	<b>max 2400 m/min</b>
Threading channel:	<b>4.5 mm</b>
Yarn count range:	<b>6 Nm - 10 dTex</b>
Noise level:	<b>&lt; 70 dB A</b>
Weight:	<b>8 kg</b>
Working temperature:	<b>from 10 ° to 40 °C</b>
Storage temperature:	<b>from -25 ° to +65 °C</b>
Relative humidity:	<b>max 95% (not condensed)</b>

### Pulsar HP brake description

The Pulsar HP device, performs the following two functions:

**Breaking function:** to reduce the tension pick to the weft when the same is stopped by the Electromagnet pin. This is to avoid the following problems:

- a. weft breakage at the end of the insertion
- b. weft loops or slack picks in the fabric.

**Pull back function:** after the yarn cutting, yarn is pulled back into the nozzle. This is to avoid that the weft gets tangled in the next weft to be inserted by the contiguous nozzle.

### Technical data of Pulsar HP

Cycles per minute:	<b>1.200</b>
Reaction time:	<b>7 ms</b>
Max torque:	<b>11.5 Ncm</b>
Weft pull back length:	<b>max 35 mm</b>
Eyelet's diameter:	<b>6 mm</b>

### Other information about Super Elf S3

The **Part Number (P/N)** and the **Serial Number (S/N)** are printed on the **CE label**.

## Features and Characteristics

- o The Weft Feeder can be set for rotation S or Z depending on the yarn twist.
- o Yarn separation is adjustable from 0.7 mm to 2.2 mm.
- o Coils detection by means of photocells (Reflective system).
- o Storage detection with an integrated photocell (Reflective system).
- o Robust and reliable new Reflective sensors system.
- o Input Weft breakage control through a photocell integrated in the Super Elf S3, or through external TFE8 weft Stop Motion device.
- o Weft length adjustment, by setting the spool body diameter and the number of coils to be released at each insertion.
- o Range of weft lengths: from 64 to 672 cm.  
*Note: Weft lengths ranging from 87 to 96 cm CANNOT BE MEASURED.*
- o CAN BUS communication protocol with the loom Control.
- o Pulsar HP brake control.
- o Full and half weft threading by means of a pneumatic system.
- o New Electromagnet design.
- o Reserve Storage position Photocell reliable also in dust environments.
- o Permanent Magnet motor for more accurate speed control, faster acceleration, full torque at all speeds and lower energy consumption.
- o Sealed motor, photocells housing and cable connections are IP63 Water Proof standard
- o New anti-balloon design with reclining Funnel simplifies maintenance and optimizes space requirements for multi-color applications.

## 2. SETTING AND CONTROL ELEMENTS

### Front Control elements

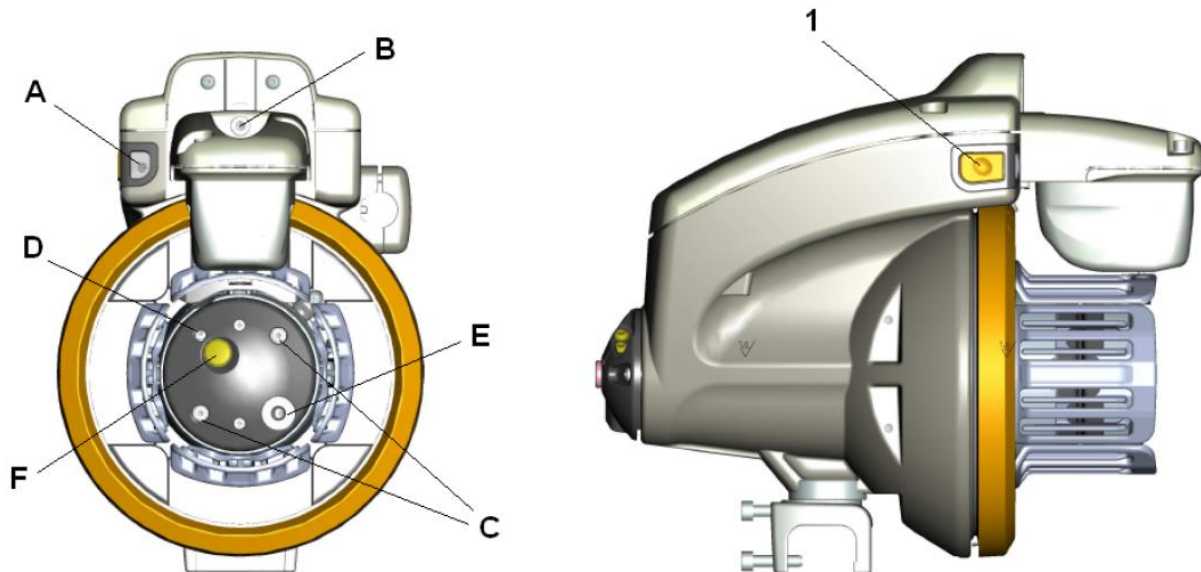

#### 1 FUNCTION BUTTON

It activates the Electromagnet and allows the following operations:

- a- Weft reserve removal.
- b- New weft reserve loading.
- c- Release of only one coil when the weft reserve is already on the Spool Body.
- d- Photocells calibration
- e- Reset of the fatal errors without switching OFF the main power.

#### A SIGNALING LED

When the weft feeder is powered, the led turns on if no faults are detected. In case of problems, the led blinks. Slow blinking in case of warnings, fast blinking in case of fatal errors.

#### B ADJUSTMENT SCREWS FOR THE ELECTROMAGNET POSITION

#### C, D, E ADJUSTMENTS SCREWS OF SPOOL BODY DIAMETER (Coil length)

#### F PUSH BUTTON FOR SETTING OF WINDING DISC ROTATION DIRECTION AND COILS SEPARATION

## Back panel control elements

### 1 CONNECTION OF AIR LINE INPUT

### 2 CONNECTION OF AIR LINE FOR FULL AIR THREADING

Full air threading is possible only in combination with Funnel. If the feeder is fitted with eyelet holder, or without any balloon control, this connection must be closed with relevant plug that it is supplied with the feeder.

### 3 HALF THREADING BUTTON

Insert the yarn into the eyelet and press the half threading button (3), whilst lightly holding the yarn.

### 4 FULL THREADING BUTTON

Insert the yarn into the eyelet and press the full threading button (4), whilst lightly holding the yarn.

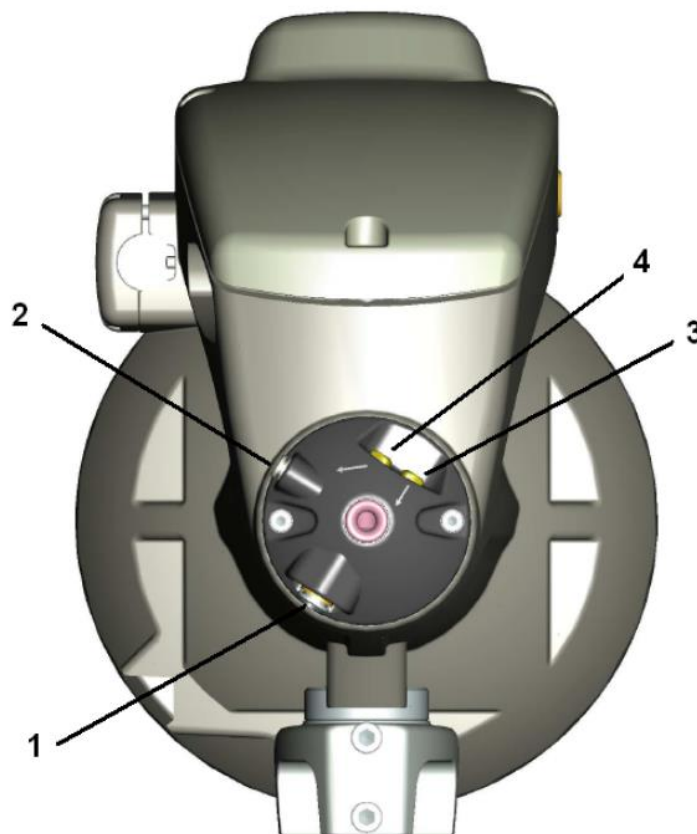

### 3. INSTALLATION AND CONNECTION

#### Voltage Supply Box and Weft Feeder installation

1. Fix the Voltage Supply Box to the Stand by means of the proper brackets.

**Note:** *Minimum distance from the Box to the floor must be 20 cm. (see fig.1)*

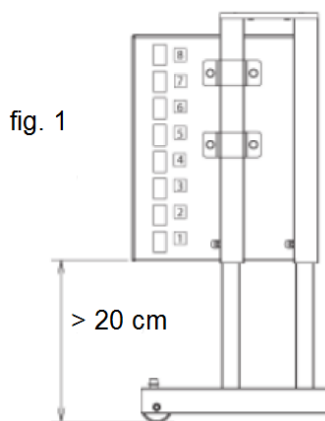

2. Install the Weft Feeders on the Stand by means of the existing clamps.

**Note:** *The feeders must be positioned on the stand according to the type of installation. It is important that yarn path is as straight as possible between the Feeders and the loom nozzles.*

3. Place the Feeders' cables and the air tubes inside the tunnel of the Stand.

#### Electrical connections

1. Connect the Feeder's cables to the Voltage Supply Box by following the numeric correspondence to the loom nozzles (Feeder working with the weft threaded in nozzle 1 must be connected to the position 1 of the Voltage Supply Box; etc.).

2. Connect the CAN BUS cable to the loom (see fig.2 page 8).

3. Feeder's Stand and Creel must be connected to the earth of the loom.

4. Connect the plug of the 3-phase power cord to the socket on the loom main control cabinet (MCC). See fig.2 page 8.

**Warning!** *The connection between the Voltage Supply Box and the 3-phase power supply network must always be as stated on the following page. In this way, the loom main switch performs also as main switch for the Weft Feeders (see fig. 2 page 8).*

**Note:** *The Voltage values supplied to the Weft Feeders can be checked on the Voltage Supply Box connectors (see fig. 3 page 8).*



fig. 2

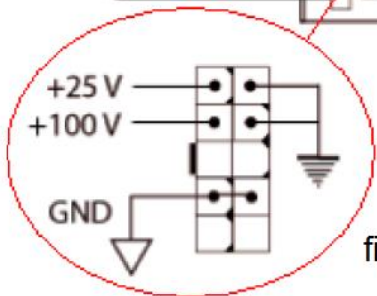
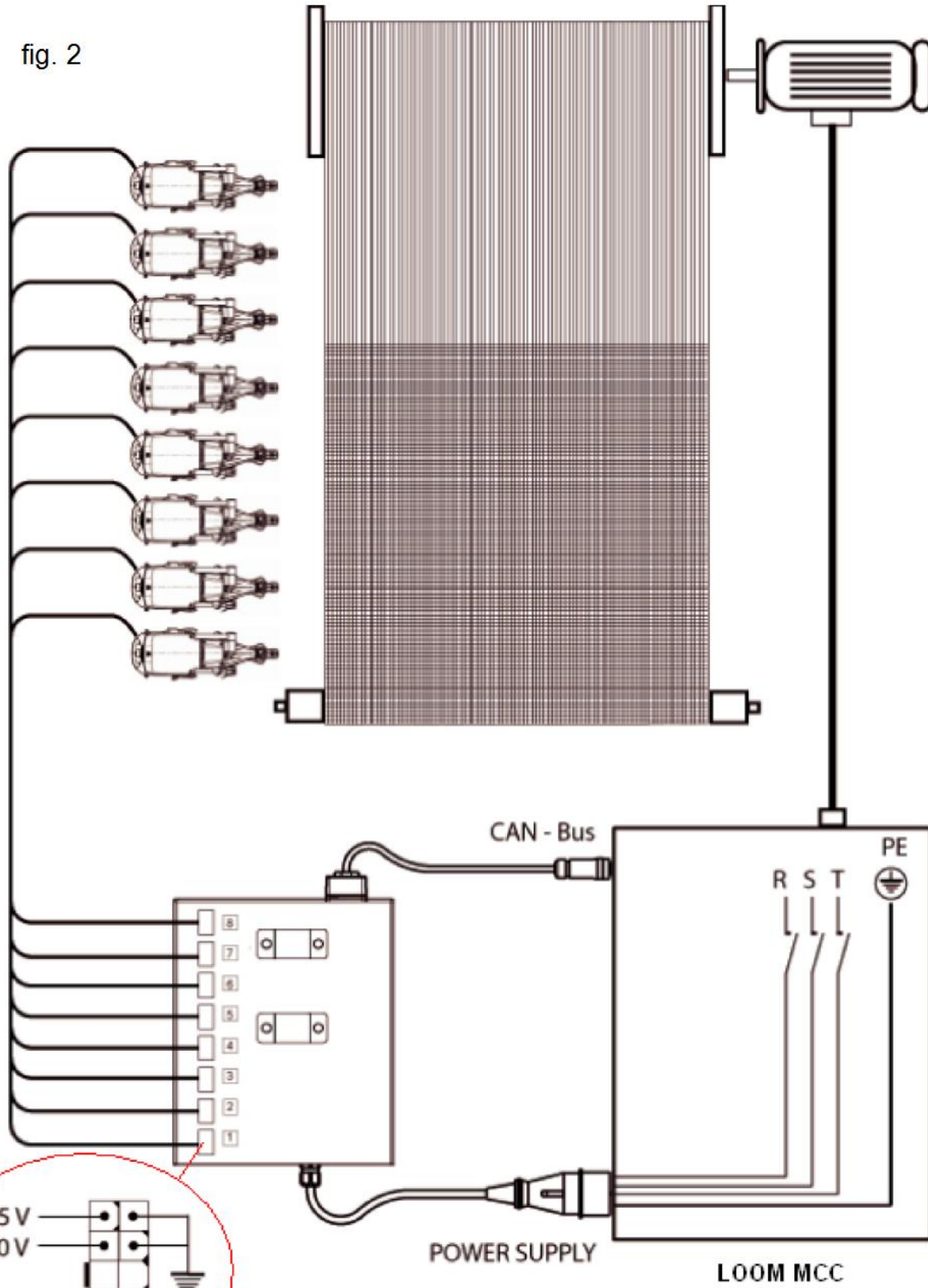

fig. 3

## 4. SETTINGS AND OPERATION

### How to set working parameters

1. Turn the loom main switch ON. The feeders are now supplied with power and receive the setup data from the loom Control (wait for about one minute).

2. The pulsar calibration cycle is then automatically performed. If no faults occur, the signaling led, on the front side of the feeder, remains ON. In case of faults, the led blinks and a fault message is shown on the loom Dialog panel display.

**Note:** Before switching the loom power ON, always verify that the pulsar fork (F) is free to move and therefore avoid:

- Yarn tied to eyelet holder or any other machine part
  - Yarn inserted into the fabric and not cut
- The yarn can be kept firmly by loom controlled devices as these are synchronized with the Pulsar calibration function. To reset the error "**Pulsar not calibrated**", switch the loom OFF, make sure that the Pulsar fork is free to move, then switch the loom back ON.

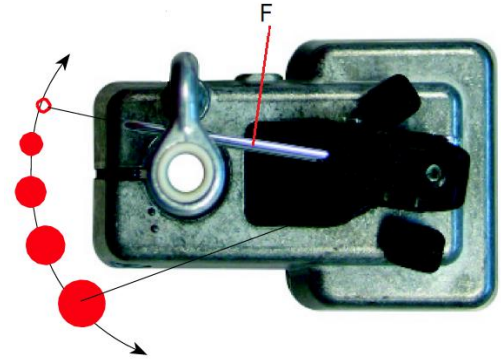

3. According to the woven article, adjust the functioning parameters of Super Elf S3, which can be set on DORNIER loom Dialog panel (see picture below).

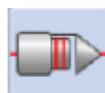
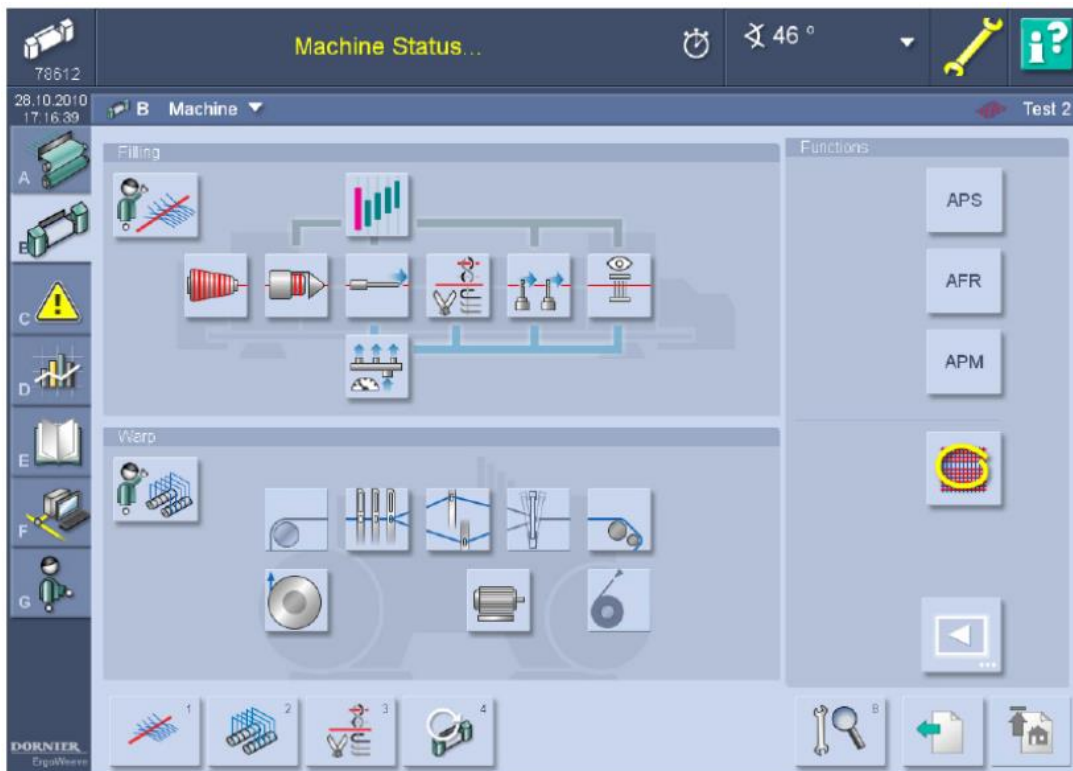

4. Press the icon  to enter the feeder pages.

**Insertion length**



To set the number of coils (windings) to be released by the Feeder at each pick.

- Possible setting: **2 -> 16**.
- Recommended setting: see note

***Note:** the setting “Insertion Length” is dependent on the “Reed width” parameter which is under the “Weft Insertion” menu. It is recommended to make the Feeder operating with the Drum set to the wider diameter and releasing the minimum number of coils possible (see table below for reference).*

Spool Body Size	Number of coils released for each insertion							
	2 coils	3 coils	4 coils	5 coils	6 coils	7 coils	8 coils	9 coils
A	68 - 72	96 - 108	128 - 144	171 - 180	206 - 216	241 - 252	275 - 288	310 - 324
B	73 - 75	109 - 112	145 - 150	181 - 187	217 - 225	253 - 262	289 - 300	325 - 337
C	76 - 78	113 - 118	151 - 157	188 - 196	226 - 235	263 - 274	301 - 314	338 - 353
D	79 - 82	119 - 123	158 - 164	197 - 205	236 - 246	275 - 287	315 - 328	354 - 369
E	83 - 85	124 - 127	165 - 170	206 - 212	247 - 255	288 - 297	329 - 340	329 - 382
	<b>10 coils</b>	<b>11 coils</b>	<b>12 coils</b>	<b>13 coils</b>	<b>14 coils</b>	<b>15 coils</b>	<b>16 coils</b>	
A	344 - 359	378 - 396	413 - 432	442 - 468	476 - 504	510 - 540	544 - 576	
B	360 - 374	397 - 412	433 - 450	469 - 487	505 - 525	541 - 562	577 - 599	
C	375 - 392	413 - 431	451 - 470	488 - 510	526 - 549	563 - 588	600 - 627	
D	393 - 410	432 - 451	471 - 492	511 - 533	550 - 574	589 - 615	628 - 656	
E	411 - 425	452 - 467	493 - 501	534 - 552	575 - 595	616 - 637	657 - 680	
<b>Range of length inserted (in cm)</b>								

**Reserve Sensor**



**Automatic = ON**



**Automatic = OFF**

When this is set to Automatic = ON, the Reserve Sensor automatically regulates the take-off point at a fixed position.

- Possible setting: **Off, 0, 1, 2**

**Off** - Automatic position control deactivated

**0** - Automatic position control activated with lower reserve storage

**1** - Automatic position control activated with standard reserve storage

**2** - Automatic position control activated with maximum reserve storage (the take-off point is nearby the stopper pin)

- Recommended setting: **1**

**Reserve windings (to be set when Automatic = OFF)**

It sets the number of coils to be wound on Spool body when a new Reserve is loaded. Set the highest number of coils possible, avoiding them to overlap each other nearby the stopper pin (the reserve has to be over 3/4 of the spool body length).

- Possible setting: **12 -> 68.**
- Recommended setting: according to the yarn count, set the coils pitch as low as possible.

*Note: In case of different reserve position between Feeders, set with the same number of coils and make them equal by adjusting the coils pitch.*

**Filling Tensioner (Pulsar HP)**

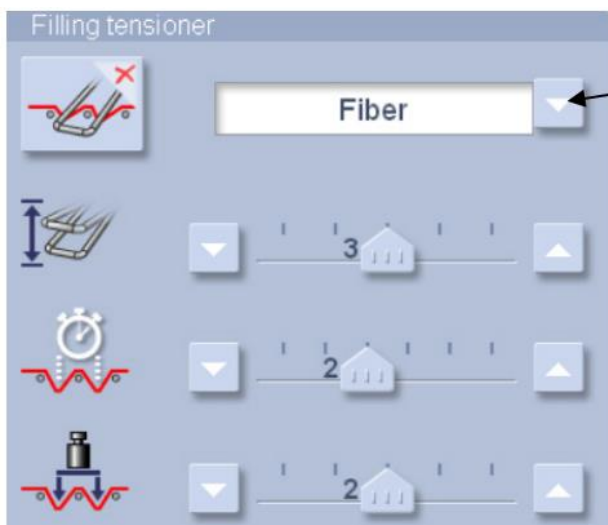

**Set here the Yarn type**

Possible settings:

- **fiber**
- **filament < 500dTex**
- **wool**
- **filament > 500dTex**

The Pulsar HP will automatically use the factory pre-settings according to the chosen yarn type



**Stroke**

This parameter allows set the stroke angle value:

- Possible setting:

**off** brake disabled

**1** minimum stroke angle

**2** low stroke angle

**3** middle stroke angle

**4** high stroke angle

**5** maximum stroke angle

- Recommended setting:

**2** it gives a low reduction of the end insertion tension peek. (The yarn speed reduction at the arrival is very low).

**3** it gives a good reduction of the end insertion tension peek. (The yarn speed reduction at the arrival is low).

**4** it gives a very good reduction of the end insertion tension peek. The yarn speed reduction is very high and the arrival is very irregular).

**Note:** Use the "1" and "5" values only in extreme cases:

**1** - when the important is to avoid to slow down the yarn at the arrival. (The reduction of the end insertion tension peak will be very low).

**5** - to reduce the end insertion tension peek as much as possible. (The yarn speed reduction is very high and the arrival is very irregular).



### Duration

This parameter set the duration of braking function.

- Possible setting:

**0** the fork reach braking position at same time when the electromagnet pin stops the yarn at end of insertion

**1** minimum braking anticipation

**2** low braking anticipation

**3** middle braking anticipation

**4** high braking anticipation

**5** maximum braking anticipation

- Recommended setting:

**0, 1, 2** for filament yarns

**2, 3, 4, 5** for fiber yarns and wool



### Force

This parameter allows the user to choose between 5 force values:

- Possible setting:

**0** minimum braking force

**1** low braking force

**2** middle braking force

**3** high braking force

**4** maximum braking force

- Recommended setting: Increase the braking force according to yarn size (Yarn count). See table on next page.



Yarn type	maximum	high	medium	low	minimum
<b>Fiber</b>	[< 5 Ne] 4	[5 - 10 Ne] 3	[10 - 16 Ne] 2	[16 - 30 Ne] 1	[> 30 Ne] 0
<b>Filament</b>	[>1100 dtex] 9	[1100-550 dtex] 8	[550-300 dtex] 7	[300-150 dtex] 6	[<150 dtex] 5
<b>Wool</b>	[< 18 Nm] 14	[18 - 35 Nm] 13	[35 - 48 Nm] 12	[48 - 58 Nm] 11	[> 58 Nm] 10

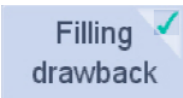

**Filling Draw back**

This parameter allows **to enable or disable** the yarn filling draw back after yarn cut. It is also possible to choose how large angle to use to pull the yarn back.

• Possible setting:

- off disabled filling draw back
- 1 minimum angle for draw back
- 2 middle angle for draw back
- 3 maximum angle for draw back

• Recommended setting: Use mostly "2" and "3" values .

**Sensors sensitivity settings**

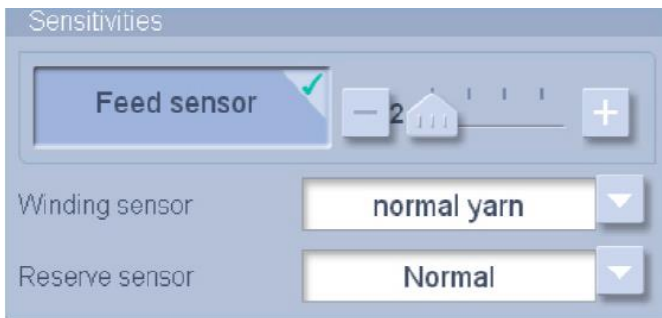

**Reaction time of the Feed Sensor**

Set the sensitivity for the photocell with function as input yarn break sensor

- Possible setting: 2, 3, 4, 5 and OFF (OFF = Feed Sensor OFF)
- Recommended setting: 3

**Note:** increase the value in case of "false" yarn break stops

**Winding sensor**

Sets the sensitivity of the photocell which is controlling the outgoing coils.

- Possible setting: normal yarn / fine yarn
- Recommended setting: normal yarn

**Reserve sensor**

Sets the sensitivity of the photocell which is controlling Automatic Reserve Position.

- Possible setting: normal yarn / fine yarn
- Recommended setting: normal yarn

**Length correction**

Avoids wrong weft length measurement due to the eventual overlapping of the coils on the Spool body.

- Possible setting: **ON / OFF**
- Recommended setting: **ON**

*Note: Set OFF in case of short picks (one coil less) with irregular insertion times.*

**Double yarn sensor**

Controls the yarn break by means of an external sensor (Roj PIEZO sensor TFE6). This is normally used in case of multiple weft insertions, i.e. when there is more than one yarn used with one feeder.

- Possible setting: **ON / OFF**

**Rotation direction**

To set the winding direction of the Feeder according to the yarn twist.

- Possible setting: **Z / S**

*Note: When changing the winding direction, the coils pitch has to be changed too.*

## Maintenance

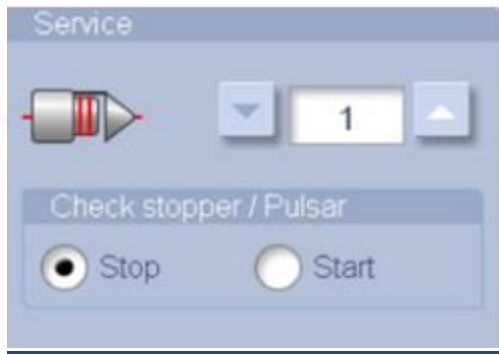

### **Stopper / Pulsar test**

This test activates a test cycle on the pulsar that will move the pulsar fork according to the settings in the Filling tensioner menu. The Stopper electromagnet is also activated.

## Photocells automatic calibration

The Super Elf S3 is fitted with an automatic photocells calibration system, which is needed when replacing the feeder circuit board or one of the sensors groups.

Proceed as follows:

1. Remove all the yarn from the spool body, and verify that the photocells glass and mirrors are clean (see below)
2. Press the Reserve push-button on the feeder side for about 30 seconds, till the LED makes a short blinking than remains steady ON: at this point the calibration is automatically performed by the feeder SW.
3. Wait a few seconds, than reset the feeder by switching the loom OFF, than back ON. Wait again until the loom has completed the normal initialization at power ON, than the feeder is ready to run.

**Note:** if the calibration procedure is made with yarn on the spool body, or with glass -mirrors dirty, the feeder can go in alarm "SYSTEM ERROR 4" and it is completely blocked. To unlock the feeder, remove the yarn from spool body, or the dust from glass – mirrors, and make the automatic calibration again. If, after performing correctly the automatic calibration, the same error is still displayed on the loom Dialog panel, proceed as here below described:

- Check the stopper pin position and distance from the spool body (see page 17)
- Check the correct connection of the photocell circuit inside the spool body
- Replace the top spool body sector (that includes the sensors)
- Replace the stopper magnet housing
- Replace the CPU board and make a new automatic calibration

## Photocells information

The Super Elf S3 works with an automatic compensation system, to grant same level of reading signals, even when the dust starts to accumulate on the window glass of the optical sensors. The amount of dust accumulated it is indicated on relevant display page.



## Weft length adjustment

The diameter of the Weft Feeder Spool Body must be set according to the indication shown on the loom Dialog panel display.

Proceed as follows:

1. Loosen the screw **B** and raise the Photocells/Electromagnet Group. Fix it.
2. Loosen the both **C** socket head screws (3 mm socket).
3. Turn the Winding Disc until the eyelet is in the upper position.
4. Loosen the **D1** socket head screw (3 mm socket).
5. Turn the Winding Disc until the eyelet is in the lower position.
6. Loosen the **D2** socket head screw (3 mm socket)
7. Adjust the diameter of the Spool Body by turning the **E socket screw (5 mm socket screw with the hole for D1 screw)** in order to move the sectors of the Winding Group to the requested reference according to weft length to be inserted (see page 10).
8. Turn the Winding Disc until the eyelet is in the lower position.
9. Tighten the **D1 and D2** socket head screws (3 mm socket) to block the fixed sectors (remember to center the hole on the screw head, **points 3 and 5**).
10. Check that the movable sectors are centrally positioned in respect with the fixed ones.
11. Tighten the two screws **C** to block the movable sectors.
12. Turn the Winding Disc and check that no movable sectors get in contact with the fixed ones; this is in order to avoid possible damages when the feeders is in operation. If the sectors get in contact, use the **C** screws to adjust the movable sectors.
13. Loosen the screw **B** and position the Photocells/Electromagnet group so that the distance between the Electromagnet and the Spool Body is about 1-1.2 mm (see picture below on the right - use the special gauge supplied with the feeder).
14. Load the reserve as described on page 18.
15. Start up the loom and check if the length weft is as required. If it is too long, decrease a bit the spool body diameter. If it is too short, increase a bit the diameter.

**Note:** Fixing torque recommended for the screws **D1, D2** and **C** = 2.3 Nm ± 10%

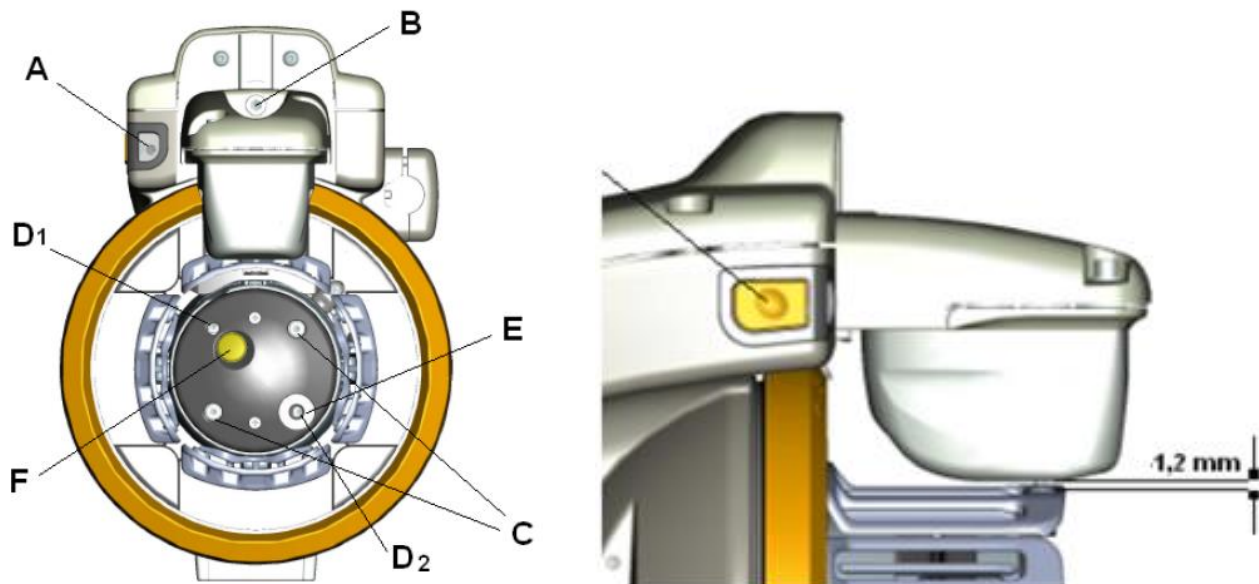

## Winding direction and coils pitch adjustment

The winding direction (S or Z) must be adjusted according to the yarn twist. Correspondence is needed between the motor electric setting and the mechanical one of the Spool Body.

Proceed as follows:

1. Press the yellow Separation push-button **F** placed in front of the Spool Body and simultaneously turn the Winding Disc until you hear a “click” (the yellow pushbutton is entered in a slot).
2. While keeping pressed this push-button, turn the Winding Disc up to the chosen position (the ceramic eyelet indicates the position). Release the push-button.

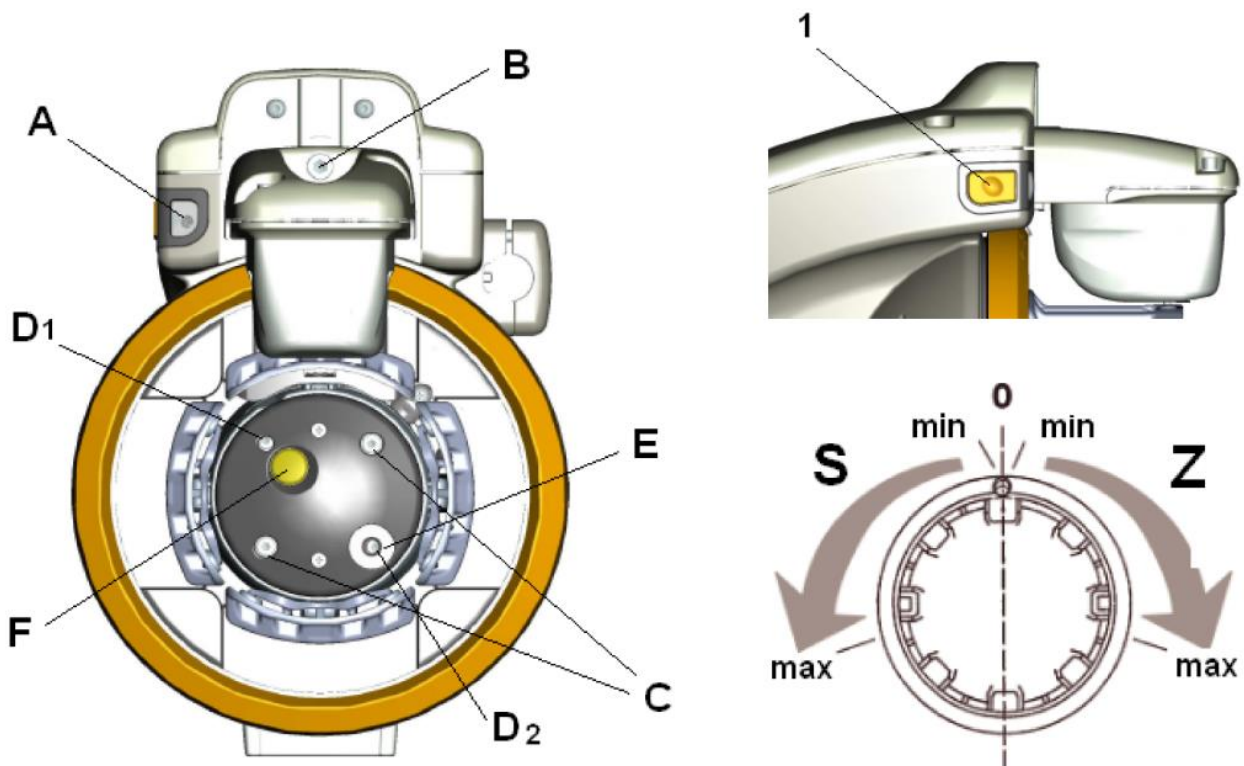

**Note:** The coils pitch must be adjusted according to the yarn count. In case of working with Automatic Reserve set to OFF, set the Reserve Windings value on the loom Dialog panel by avoiding excessive accumulation of coils in front of the Spool Body.

3. Select the winding direction rotation on the loom Dialog panel: the magnet pin goes up allowing removal of the reserve from the Spool Body. In the meanwhile, the eyelet of the Winding Disc moves to the threading position.
4. Press the start push button **1**, the Electromagnet pin goes down and the weft reserve is loaded.

## **Reserve loading (Full threading, only with funnel)**

1. Press the start push-button **1** on the side of the feeder for more than 3 seconds: the Electromagnet pin goes up and the Winding Disc automatically moves to the threading position.
2. Release a few coils from the package and keep the yarn end near the input threading eyelet, than press the full threading button **4** to thread the weft through the feeder body out to the pulsar (if the old reserve is still on the spool body it will be automatically blown out).
3. Press the key in the front of the feeder a second time: the Electromagnet goes down and the Feeder loads the reserve.

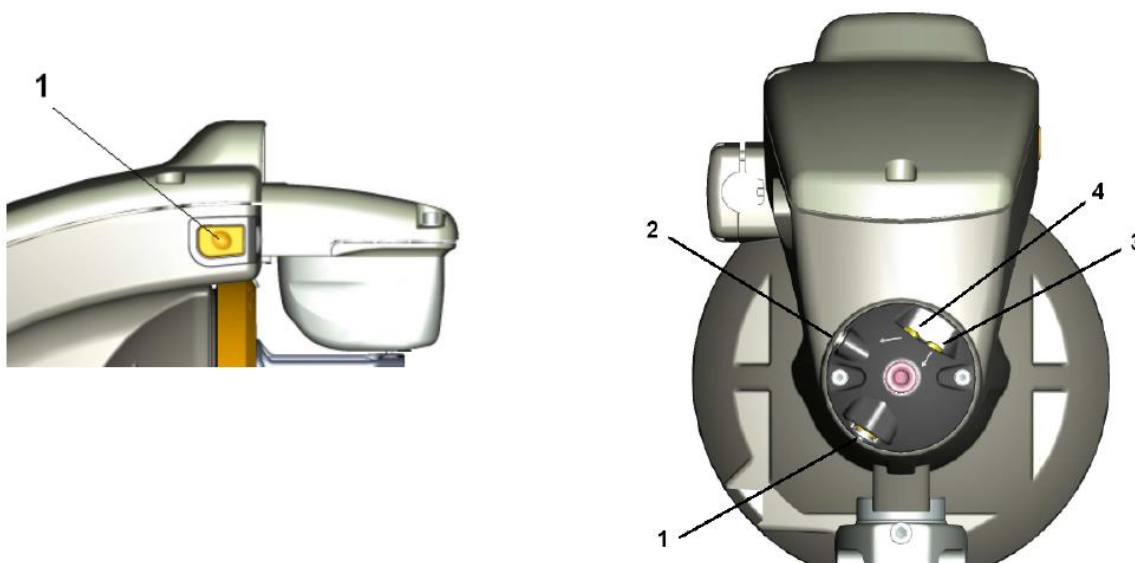

## **Weft reserve repair (Half threading)**

If during the Feeder operation, a weft breakage occurs at Feeder's entry, proceed as follows:

1. Release a few coils from the package and keep the yarn end near the input threading eyelet, than press the half threading button **3**, so that the weft is blown to the output of the winding disk without affecting the existing reserve on the Spool Body. This operation allows the weft to be knotted to the existing reserve.
2. Press the start push-button **1** on the front of the feeder in order to reset the weft breakage error. The feeder will restore the complete weft reserve.

## 5. TROUBLESHOOTING

### Description

All error messages from Super Elf S3 are shown on the display of Loom Dialog panel.

*Note: Details to fault analysis and fault repair are possible to find in the Dornier Documentation "Dialog Panel Ergo Weave" in chapter 4 "Messages"*

The Feeder will also give an alarm by means of the signaling LED (see page 4). The LED is steady ON during the normal operation of the Feeder. It is fast flashing in case of Heavy Alarms (i.e. the feeder cannot continue to work), or it is slow flashing in case of Warning Alarms (i.e. the feeder can continue to work, but some maintenance or checking is required)

**In case the loom Control panel will display “ Feeder n. ... SYSTEM ERROR 4” please refer to the Automatic photocells calibration described on page 15.**

**6. ACCESSORIES**

**Funnel P/N 54R01117R**

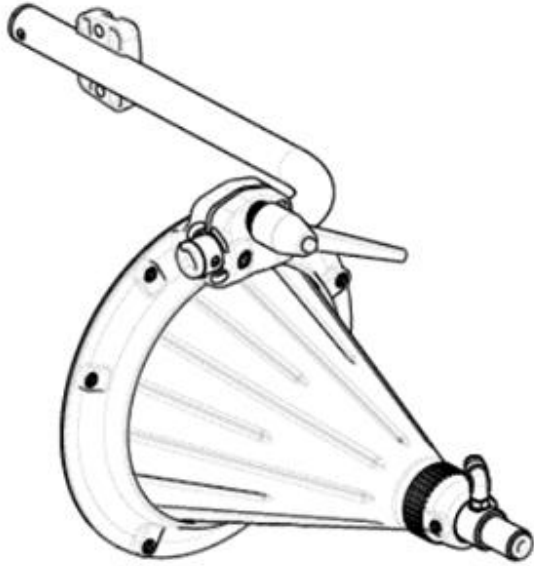

**Pulsar HP P/N 52R00109R**  
(with chromed fork)

**Pulsar HP P/N 52R00111R**  
(with ceramic fork)

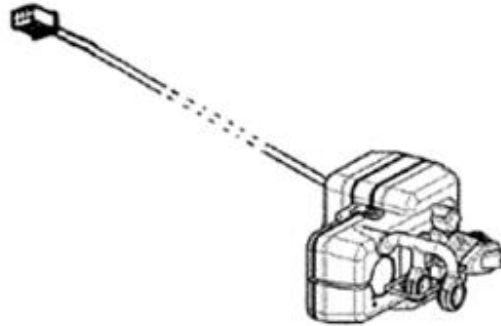

**Eyelet holder P/N 54R00430R**

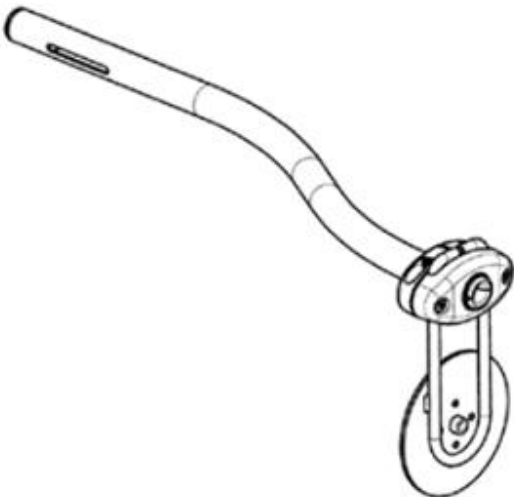

**Eyelet holder + bracket P/N 54R00432R**

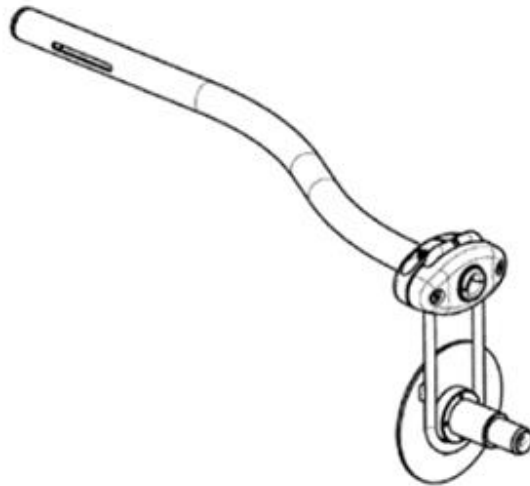

# Voltage Supply Box

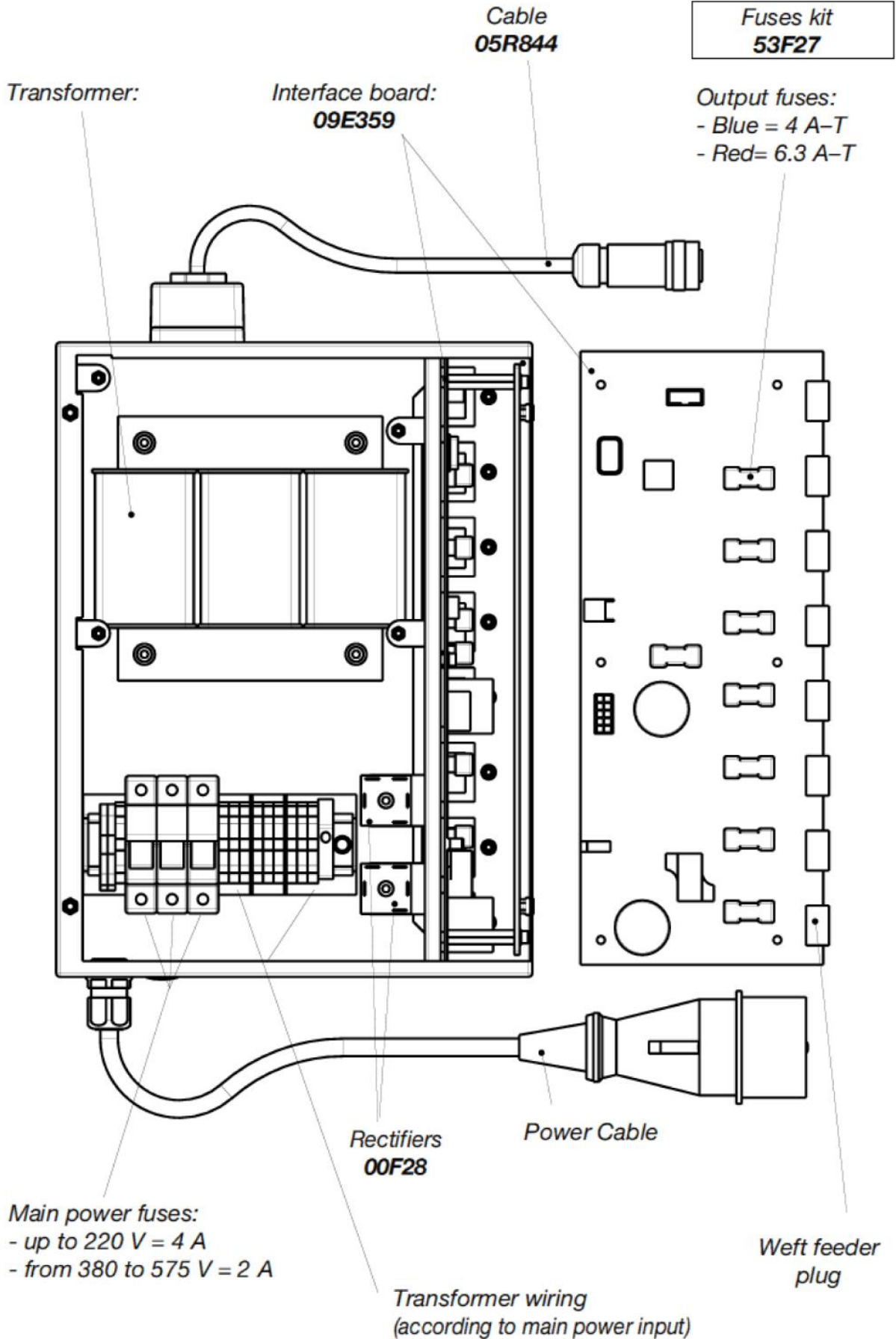



## DICHIARAZIONE CE DI CONFORMITA' EC DECLARATION OF CONFORMITY

EG-KONFORMITÄTSERKLÄRUNG – DECLARATION CE DE CONFORMITE – DECLARACIÓN DE CONFORMIDAD CE - DECLARAÇÃO CE DE CONFORMIDADE – EG-FÖRSÄKRAN OM ÖVERENSSTÄMMELSE – EC CONFORMITEIT

### IL FABBRICANTE - THE MANUFACTURER

Der Hersteller – Le fabricant – El fabricante – O fabricante – Fabrikanten – De fabrikant

**ROJ S.r.l – Via Vercellone, 11 – 13900 Biella – Italy**

### DICHIARA CHE IL PRODOTTO – DECLARES THAT THE PRODUCT

erklärt daß das Produkt - déclare que le produit - declara que el producto - declara que o produto - försäkrar att produkten - verklaart dat met product

• SUPERELF X3	• SUPERELF S3
• SUPERELF X2	• LOW TWIST X3
• SUPERELF G2	• DART G2

### E' conforme alle Direttive – Complies with the Directives:

Im Einklang mit den Richtlinien - Conforme aux directives - Cumple con las directivas - Está em conformidade com as directivas - Overensstemmelse med direktiverne - Voldoet aan de richtlijnen:

Riferimento / Short name	Direttiva numero / Directive reference	Norme / Standards
Sicurezza dei macchinari Safety of machinery	2006/42/CE	UNI EN ISO 12100: 2010
Apparecchiature a bassa tensione Low voltage equipments	2014/35/CE	CEI EN 60204-1 : 2016
Compatibilità elettromagnetica Electromagnetic compatibility	2014/30/CE	CEI EN 61000

Persona autorizzata a costituire il fascicolo tecnico, custodito presso ROJ srl, Biella /  
Person authorized to set up the technical file, guarded at ROJ srl : **Ing. Paolo Ricci – R&D director**

**Biella, 23 luglio 2020**

**Franco Oliaro**  
Managing Director