

Features

- Designed for 12V agricultural equipment
- **Suitable Precision Planting vSet® seed metering unit**
- Integrated brushless motor drive
- Signaling LED
- 2 digital inputs (e.g. seed sensor or hopper level sensor)
- GORE vent

Applications

The DMD2 54T01138 is an application specific brushless motor with integrated gearbox and electronic drive. The motor can be used to replace mechanical transmissions in precision planters metering units by Precision Planting vSet®



DMD2PP- 54T01138

Assembly Instructions

Connector AMP AMPSEAL 1-776267-1

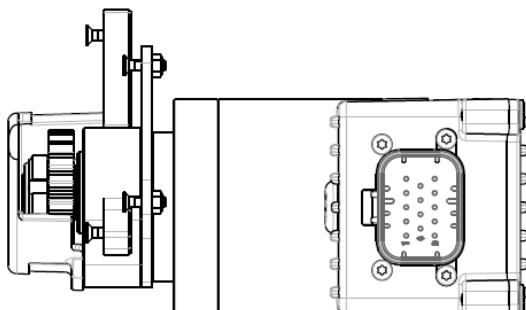
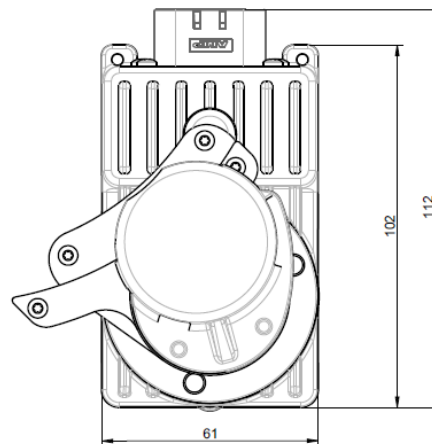
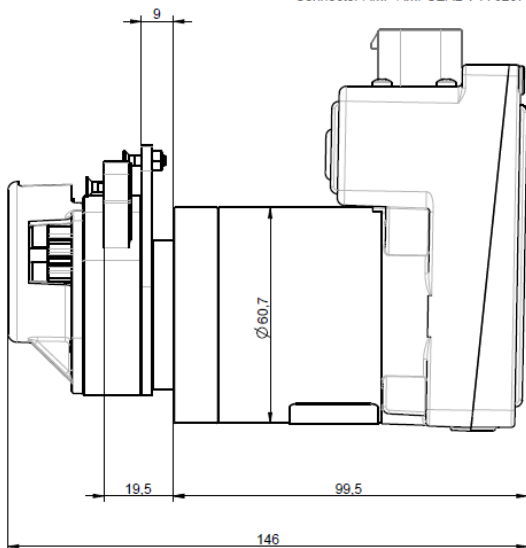

Dimensions in mm.

DMD2- 54T01138

Technical Specifications

For more details please refer to DMD2 Installation, Operation and Maintenance Manual

Environmental Specifications

Operational Temperature:	-10°C...+55°C (full specs) -10°C...+70°C (derated)
Storage Temperature:	-40°C...+80°C
IP grade	IP65 excluding the front flange/output shaft. Note: the system integrator shall provide means of protecting those surfaces when integrating the motor into the machine
Vibrations	Sinusoidal vibration test: IEC 600-68-2-6 Random vibration test: IEC 600-68-2-64 Temperature change test: IEC 60068-2-14 Shock test: IEC 600-68-2-27

Mechanical Specifications

Nominal Torque at vSet® output shaft	1,5 Nm
Peak Torque at vSet® output shaft	4 Nm (single pulse, duration 500ms)
Nominal Speed at vSet® output shaft	106 rpm
Gear ratio of integrated gear + vSet® disk gear	19,76:1
Gear output shaft	z20 m1,5875 ap20°

Electrical Specifications

EMC	The unit fulfills EN ISO 14982: 2009 standard (Agricultural and forestry machinery)
Supply voltage	11-16V Note: Voltage is intended at MD connector input pins. Voltage drop due to cable harness shall be taken into account.
Supply current (at nominal Torque, nominal Speed and minimum supply voltage)	6A

Input/output and communication

CAN	1 CAN bus line (compliant ISO SO 11898-2 and 5. Up to 1 Mbit/s)
Sensor interface	2 x inputs: 3 pin (8V – 80mA supply, GND, signal), up to 2,5 kHz suitable for NPN output sensors.
Safety switch input	Contact switch input to remove supply to power stage.
Daisy Chain CAN addressing line	Input and output signal for automatic CAN node assignment

Disclaimer

The present specifications are intended to be preliminary. Parameters and values indicated in the document might be subjected to changes. For further information, please contact: mechatronics@roj.com

INSTALLATION INSTRUCTIONS

General principles

1. A Torx T10 screwdriver and a 5.5 mm spanner are required to complete the motor assembly
2. Remove front seeder disk group of the precision planters metering units, remove the disk
3. Put the motor in correct position (see picture) and fix it to the seeding unit with two screws from the kit (red arrows), do not tighten them fully yet



4. Insert another two screws in the internal position (see red arrow in the first picture)
5. Screw the two nuts onto the second set of screws from the opposite side (see red arrow in the second picture) and tighten them all firmly

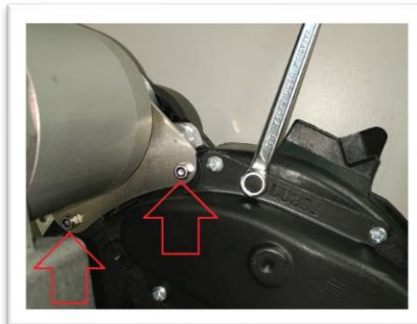

6. Assemble the seeding disk and close the planters metering unit (Lift the rubber cover with your finger during this operation)



Water protection

Motor protection degree: **IP65**, excluding the front flange/output shaft.

The system integrator shall provide means of protecting this surface when integrating the motor into the machine

Output connector

The output connector on the motor is a AMP Ampseal 14 poles, with the following pin assignment:

Pin	Signal	Pin	Signal
1	POWER +12V	8	MOTOR_ENABLE_OUT(*)
2	GND	9	SEED_SENSOR_CNT(*)
3	SENSOR_POWER (8V- 80mA)	10	CAN_SYNCHR_OUT
4	SENSOR_POWER (8V- 80mA)	11	CAN_SYNCHR_IN
5	AUX_IN	12	MOTOR_ENABLE_IN
6	CAN_H	13	SENSOR_GND
7	CAN_L	14	SENSOR_GND

It matches with connector **AMP Ampseal 776273-1**.

ROJ can supply standard motor cable harnesses in various lengths and power distribution boxes.

(*) Safety switch

A safety switch shall be connected to signals MOTOR_ENABLE_IN/ MOTOR_ENABLE_OUT. If the contact is open, the DMD0 cannot rotate. The safety switch must be implemented using:

- an electro-mechanical switch with “positive opening” NC contact (condition indicated by the symbol ⊕), or
- an electromagnetic sensor with high reliability (e.g. SICK RE11-SA03 or equivalent)

In order to ensure the requested safety level (Performance Level = c according to EN ISO 13849-1), it is necessary to provide a safety contact with the following characteristics:

- B10d $\geq 2 \times 10^6$

Note: B10d is the reliability parameter declared by the device Manufacturer that corresponds to the number of switching operations guaranteed without errors.