

Features

- Designed for 12V agricultural equipment
- 4,5 Nm, 80 rpm @ output shaft
- Custom versions upon request.
- CANOpen communication (speed and position control)
- Integrated brushless motor drive
- Signalling LED
- 2 digital inputs (e.g. seed sensor or hopper level sensor)
- GORE vent
- **ROJ protocol (54T01135) or Arag protocol (54T01136) variants**

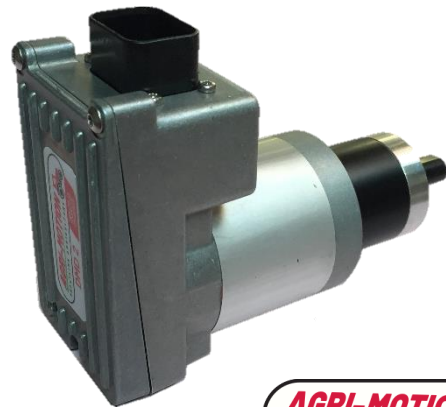

Applications

The DMD2 is an application specific brushless motor with integrated planetary gearbox and electronic drive. The motor can be used to replace mechanical or hydraulics transmissions in agricultural or other off-highway applications (e.g. variable rate applications).

Application example are:

- Actuation of seeding element in pneumatic precision planting machines
- Actuation of seed distributor in air-drills or small grain planters
- Actuation of fertilizer and microgranular spreaders in agricultural machines
- Salt, fertilizer, grain spreaders

Overall dimensions

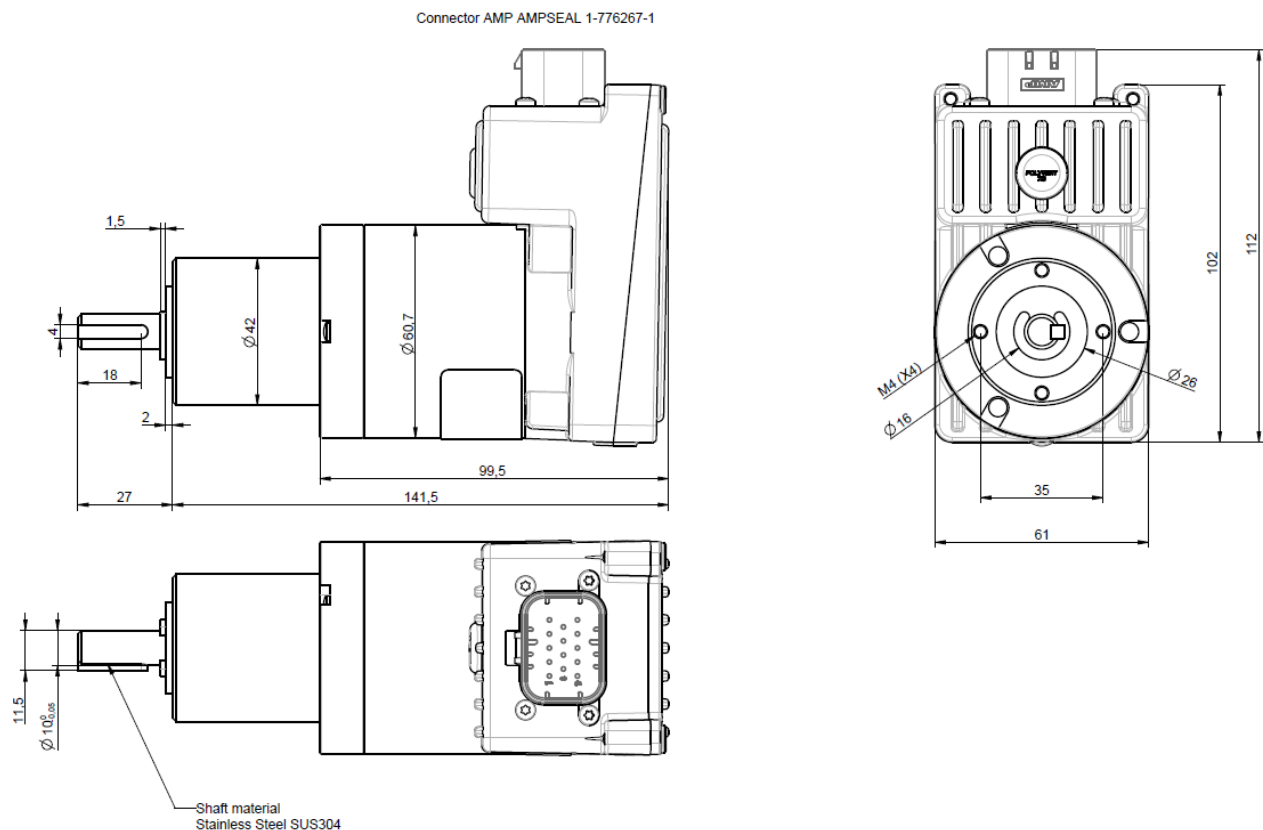

Dimensions in mm.

Environmental Specifications

Operational Temperature:	-10°C...+55°C (full specs) -10°C...+70°C (derated)
Storage Temperature:	-40°C...+80°C
IP grade	IP65 excluding the front flange/output shaft. Note: the system integrator shall provide means of protecting those surfaces when integrating the motor into the machine
Vibrations	Sinusoidal vibration test: IEC 600-68-2-6 Random vibration test: IEC 600-68-2-64 Temperature change test: IEC 60068-2-14 Shock test: IEC 600-68-2-27

Mechanical Specifications

Nominal Torque at output shaft	4,5
Peak Torque at output shaft	6,75 (single pulse, duration 500ms)
Nominal Speed at output shaft	80 rpm
Gear ratio of integrated gear	1:26.85 axial planetary gear

Electrical Specifications

EMC	The unit fulfills EN ISO 14982: 2009 standard (Agricultural and forestry machinery)
Supply voltage	11-16V Note: Voltage is intended at MD connector input pins. Voltage drop due to cable harness shall be taken into account.
Supply current (at nominal Torque, nominal Speed and minimum supply voltage)	6A

Input/output and communication

CAN	1 CAN bus line (compliant ISO SO 11898-2 and 5. Up to 1 Mbit/s)
Sensor interface	2 x inputs: 3 pin (8V – 80mA supply, GND, signal), up to 2,5 kHz suitable for NPN output sensors.
Safety switch input	Contact switch input to remove supply to power stage.
Daisy Chain CAN addressing line	Input and output signal for automatic CAN node assignment

Disclaimer

The present specifications are intended to be preliminary. Parameters and values indicated in the document might be subjected to changes. For further information, please contact: mechatronics@roj.com